

ASSEMBLY, INSTALLATION & SERVICING MANUAL FOR AMBI RAD VISION® VS RANGE OF RADIANT TUBE HEATERS

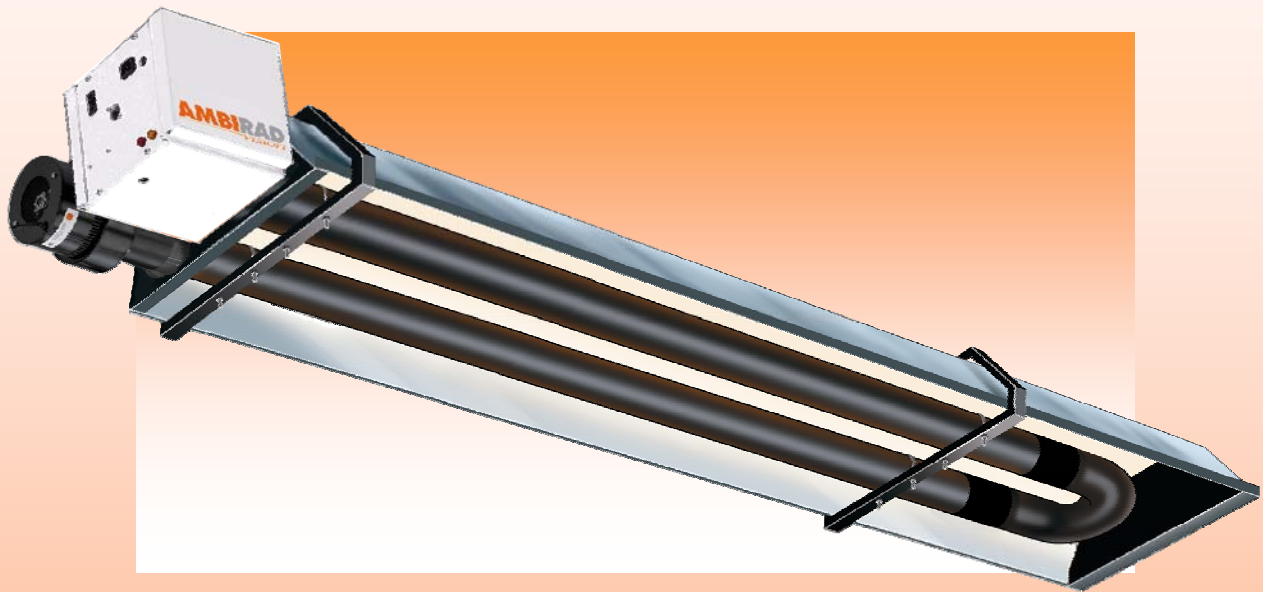

INDEX

Section

Introduction and Document Index	
Installation Requirements -----	1
Assembly Instructions -----	2
Commissioning Instructions -----	3
Servicing Instructions -----	4
Spare Parts -----	5
Fault Finding Guide -----	6
Replacing Parts -----	7
User and Operating Instructions -----	8

WARNINGS

AmbiRad equipment must be installed and maintained in accordance with the relevant provisions of the Gas Safety (Installations and Use) Regulations 1998 for gas fired products. Due account should also be taken of any obligations arising from the Health and Safety at Works Act 1974 or relevant codes of practice. In addition the installation must be carried out in accordance with the current IEE wiring regulations (BS 7671:2001), BS 6896:2005 (Industrial & Commercial) and any other relevant British Standards and Codes of Practice by a qualified installer. All external wiring MUST comply with the current IEE wiring regulations.

Introduction.

Welcome to the new range of high efficiency AmbiRad Vision radiant tube heaters. Local regulations may vary in the country of use and it is the installers responsibility to ensure that such regulations are satisfied

All installation, assembly, commissioning and service procedures must be carried out by suitable qualified competent persons to the statutory regulations in the country of use.

When assembling, installing, commissioning and servicing is undertaken on radiant tube heaters specified in these instructions, due care and attention is required to ensure that working

at height regulations are adhered to at the mounting heights specified.

 **PLEASE READ** this document prior to installation to familiarise yourself with the components and tools you require at the various stages of assembly.

All Dimensions shown are in mm unless otherwise stated.

The manufacturer reserves the right to alter specifications without prior notice.

Document Index.

1 Installation Requirements

- 1.1 Health & Safety
- 1.2 Model Definitions
- 1.3 Heater Suspension
- 1.4 Wall Mounting
- 1.5 Herringbone Systems
- 1.6 Clearance to Combustibles
- 1.7 Gas Connection & Supply Details
- 1.8 Electrical Connections
- 1.9 Ventilation Requirements
 - 1.9.1 Unflued Radiant Heater
 - Mechanical Ventilation
 - Natural Ventilation
 - 1.9.2 Flued Radiant Heater
 - Mechanical Ventilation
 - Natural Ventilation
- 1.10 Flue & Combustion Air Inlet
- 1.11 Technical Details

2 Assembly Instructions

- 2.1 Tools Required
- 2.2 Assembly Notes
 - 2.2.1 Tubes
 - 2.2.2 Turbulators
 - 2.2.3 Brackets
 - 2.2.4 U Bends
 - 2.2.5 Couplers
 - 2.2.6 Reflectors
 - 2.2.7 End Caps
 - 2.2.8 Burner Assembly
 - 2.2.9 Fan Assembly
 - 2.2.10 DL Condensate Box Assembly

- 2.2.11 HB Damper Assembly
- 2.2.12 HB Manifold Assembly
- 2.2.13 Detailed Assembly Drawings

3 Commissioning Instructions

- 3.1 Tools Required
- 3.2 Balancing the Herringbone System
- 3.3 Balancing a DL System
- 3.4 Commissioning Chart for VS Unitary Heaters

4 Servicing Instructions

- 4.1 Tools Required
- 4.2 Burner Description
- 4.3 Burner Removal
- 4.4 Burner Gas Injector Servicing
- 4.5 Burner Head and Electrode Servicing
- 4.6 Combustion Fan Assembly Induced Burner
- 4.7 Combustion Fan Assembly Forced Burner
- 4.8 Radiant Tube Servicing
- 4.9 Reflector Servicing
- 4.10 Inspection of Flue
- 4.11 Re-commissioning after Service

5 Spare Parts

6 Fault Finding Guide

7 Replacing Parts

- 7.1 Burner Controller Replacement
- 7.2 Air Pressure Switch Replacement
- 7.3 Gas Valve Replacement

8 User and Operating Instructions

- 8.1 To Start Heater
- 8.2 To Switch Off Heater
- 8.3 Routine Maintenance Between Service Intervals
- 8.4 Frequency of Servicing

1. Installation Requirements.

 Isolate any electrical supply to the heater and controller before proceeding.

1.1 Health and Safety

AmbiRad heaters must be installed in accordance with the relevant provisions of the Gas Safety (Installations and Use) Regulations 1998. Due account should also be taken of any

obligations arising from the Health and Safety at Works Act 1974 or relevant codes of practice. In addition the installation must be carried out in accordance with the current IEE wiring regulations (BS 7671:2001), BS 6896:2005 (Industrial & Commercial) and any other relevant British Standards and Codes of Practice by a qualified installer. Isolate all electrical supplies to the heater & controller before proceeding.

For your own safety we recommend the use of safety boots and leather faced gloves when handling sharp or heavy items. The use of protective eye wear is also recommended.

1.2 Model Definitions

VSUT = AmbiRad Vision U Tube heater with painted induced burner, stainless steel reflector & end caps.

VSUH = AmbiRad Vision U Tube heater in Herringbone manifold configurations with painted induced burner, stainless steel reflector & end caps.

VSLI = AmbiRad Vision Single Linear heater with painted induced burner, stainless steel reflector & end caps.

VSLF = AmbiRad Vision Single Linear heater with painted Forced burner, stainless steel reflector & end caps.

VSLH = AmbiRad Vision Linear heater in Herringbone manifold configurations with painted induced burner, stainless steel reflector & end caps.

VSDL = AmbiRad Vision Double Linear heater with painted induced burner, stainless steel reflector & end caps.

VSAUT, VSAUH, VSALI, VSALF, VSALH & VSADL = As above except: aluminised reflector with *no* end caps.

1.3 Heater Suspension

 Attachment to the heater support lugs should be made by a 'speed link', D shackle or in the case of drop rods, a closed formed hook. The hanging attachments to overhead steelwork etc. must be purpose made to good sound engineering practice or of a proprietary type fixing. They must be adequately fixed and designed to carry the whole weight of the heater. In the event of

Model	Recommended Mounting Height (m)	
	Horizontal	Inclined / wall mounted
15	4.0 - 5.0m	3.5 - 4.5m
20	4.5 - 7.0m	3.5 - 5.0m
25	5.0 - 8.0m	4.0 - 5.0m
30	5.5 - 9.0m	4.0 - 6.0m
35	6.0 - 10.0m	4.5 - 6.5m
40	6.5 - 11.0m	5.0 - 7.0m
45	7.0 - 12.0m	5.5 - 8.0m
50	7.5 - 13.0m	6.0 - 9.0m

suitable roof steelwork being unavailable, additional steelwork should be fitted to enable vertical hangers to be used for suspending the heaters.

These methods are illustrated in Figure 3.b. If there are any doubts as to the strength or suitability of roof steelwork to which heaters are to be suspended, please refer to a Consultant, Architect or owner of the building. The recommended mounting heights for AmbiRad heaters are given in the table above.

1.4 Wall Mounting

These radiant tube heaters can be wall mounted using the appropriate bracket (AmbiRad part no WMB-13-22-38).

When using the wall mounting brackets the heater must be inclined at an angle between 30° and 45°.

Table 1 Angle Mounting

Heater Size	Required angle	U Tube		Linear	
		Chain length	Eyebolt position	Chain length	Eyebolt position
15 - 30	30-35°	10 links	2	7 links	1
	45°	13 links	2	9 links	1
35 - 50	30-35°	12 links	3	8 links	1
	45°	16 links	3	10 links	1

Figure 3.a. Angle Mounting using the Wall mounting bracket

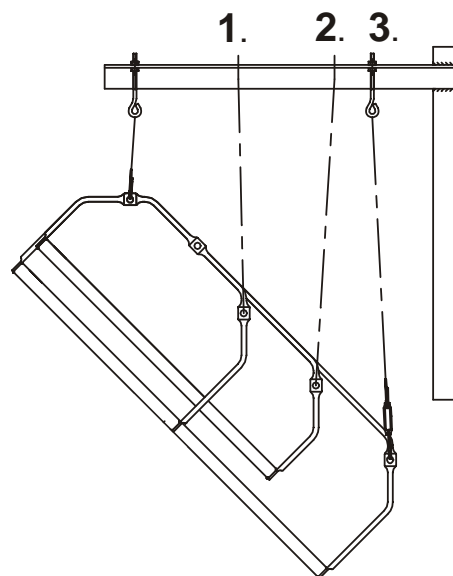
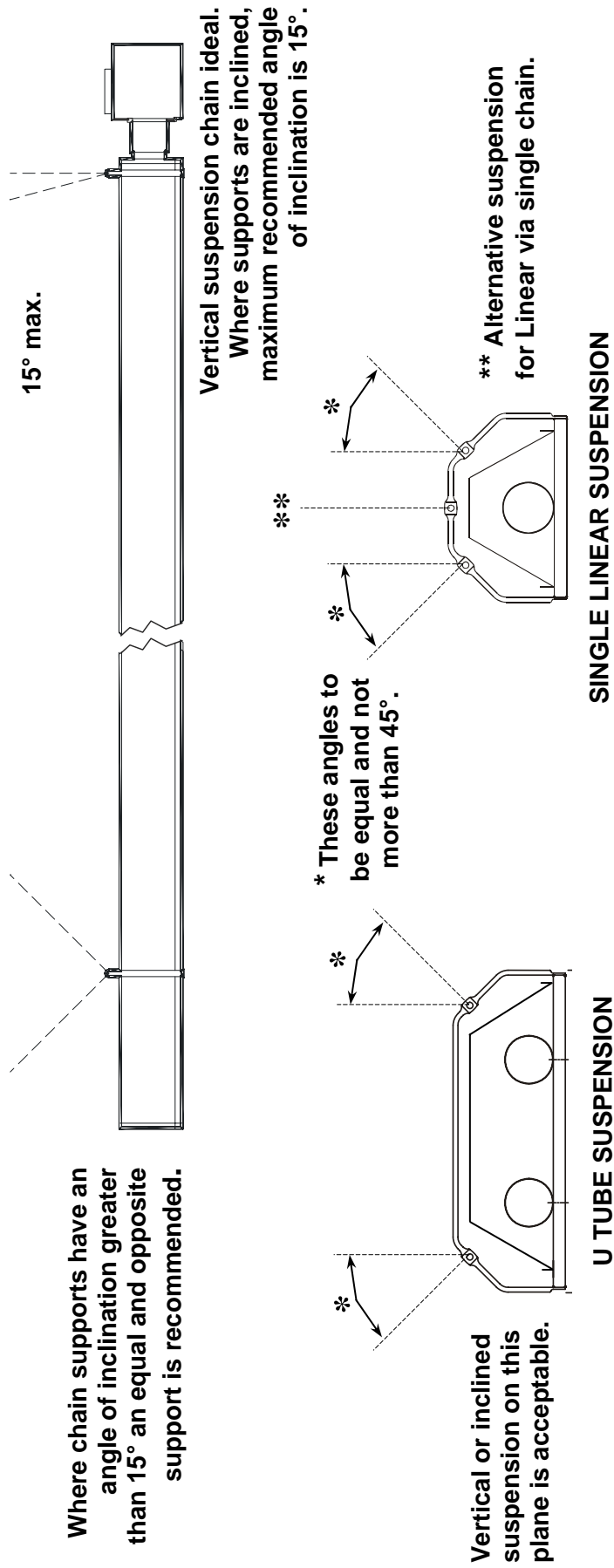
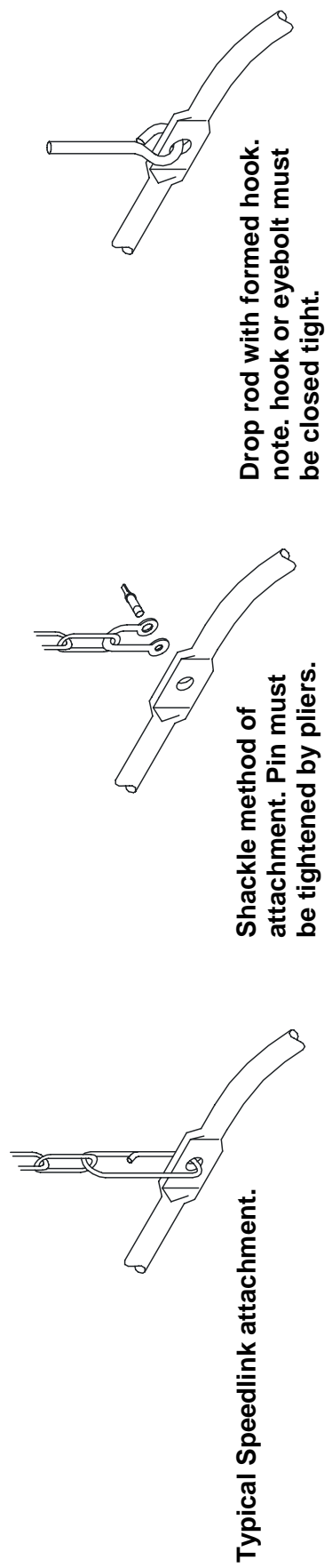

Figure 3.b. Recommended Methods of Heater Suspension.



ON U TUBE VARIANTS THE HEATER SHOULD SLOPE DOWNWARDS TOWARDS THE RETURN BEND AND ON LINEAR VARIANTS SHOULD SLOPE DOWNWARDS TOWARDS BURNER BY APPROX. 10mm FOR BOTH HORIZONTAL AND WALL MOUNTED INSTALLATIONS.



1.5 Herringbone (UH & LH models).

The manifold system should be arranged to fall slightly in the direction of the hot gas vacuum fan. This ensures that any condensation formed in the manifold on cold start and cool down is not trapped or allowed to drain back into the heater unit and will flow towards the condensate trap located at the vacuum fan end of the manifold system. (See figure 4a below for condensate trap arrangement).

The manifold should be supported by chain, stainless steel flexible wire, or other flexible means from the roof structure to allow movement caused by thermal expansion. For 100mm diameter manifold the maximum distance between supports is 2.4m and 3.0m for 150mm diameter.

Flexible couplers (supplied by AmbiRad) must be inserted within the manifold system to allow linear expansion to take place and prevent stress and strain on the system.

 The manifold must be supported either side of the flexible coupler.

The exhaust flue should be adequately supported from the building structure and installed in accordance with the British Standard Code of Practice BS 5440: Part 1:2000 – Installation and maintenance of flues and ventilation for gas appliances of rated input not exceeding 70kW net (1st, 2nd and 3rd family gases)

A condensate trap assembly must be provided at the end of the manifold system before the hot gas vacuum fan.

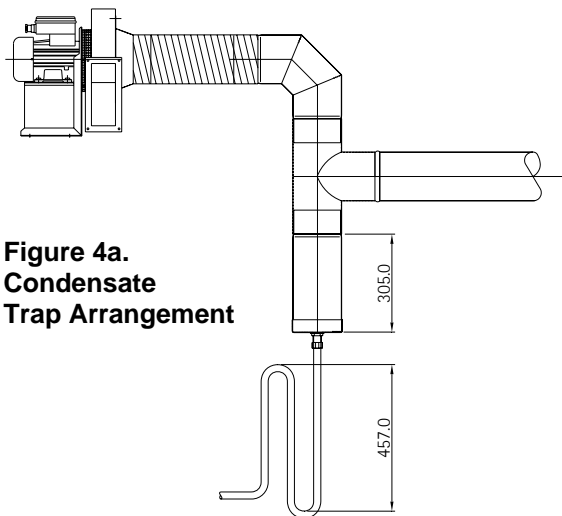

Figure 4a.
Condensate
Trap Arrangement

The minimum depth of the condensate collecting chamber shall be 305mm and the minimum depth of the condensate drain pipe

'U' trap shall be 457mm deep. The end cap of the collecting chamber to be fitted with a flush flanged tank connector. Any protrusion to be removed leaving the inside flush with end cap.

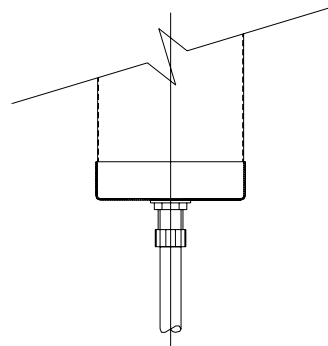

Figure 4b. Collecting Chamber Arrangement

The end cap should be sealed with silicon jointing compound and pop riveted in position. All condensate drains from the flue collecting chamber to the disposal point shall be corrosion-resistant material of not less than 22mm internal diameter. Copper or copper based alloy shall not be used for condensation drains. See reference BS 6896:2005. Condensate drain pipes must be protected against the effects of freezing.

The Type '0' and Type '2' vacuum fans have bottom horizontal discharge with rectangular connections (flanged on the type 0) and must be mounted in that position by means of the fan support stool onto a suitable platform or brackets fixed to the building structure.

For details of the fan outlet fixing holes see below.

Figure 4c. Type 'O' Fan Outlet Dimensions

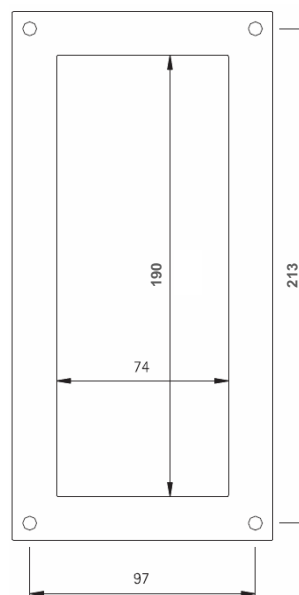
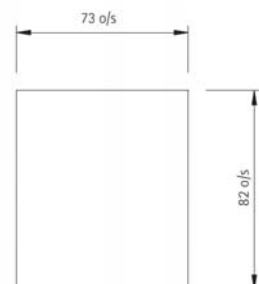

Figure 4d.
Type 2 Fan
Outlet Dimensions



For details of fan mounting bracket and fixing down holes see figure 5.

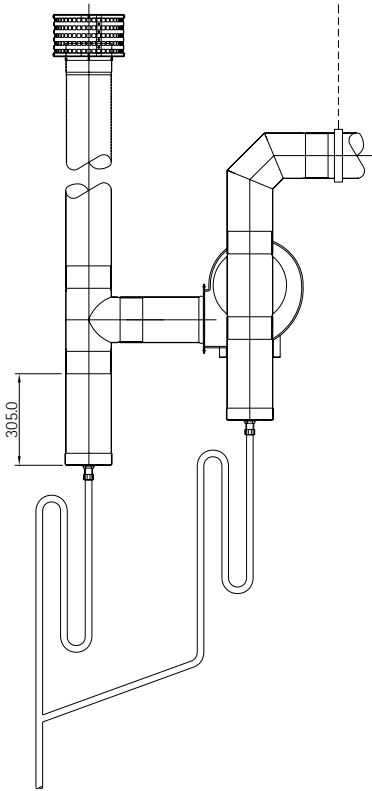

Figure 4e. Conventional Flue Arrangement Roof Exit.

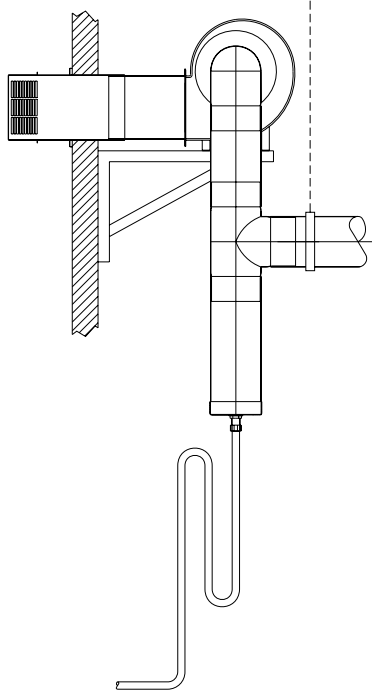

Figure 4g. Stainless Steel Telescopic Through The Wall Arrangement (available for type 'O' and Type '2' fans)

Where a conventional flue is to be installed, AmbiRad supply an aluminium transformation piece to which a 150mm (6ins) diameter flue should be attached.

The length of flue which may be connected to the fan outlet must be adequately supported from the building structure.

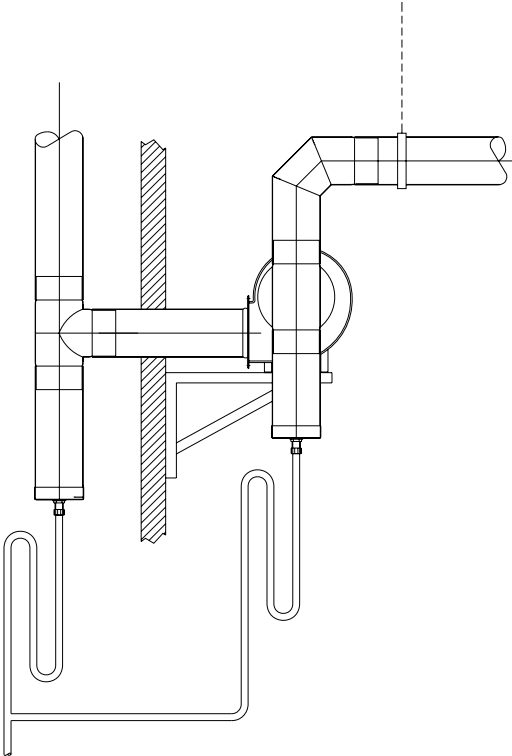

Figure 4f. Conventional Flue Arrangement Wall Exit.

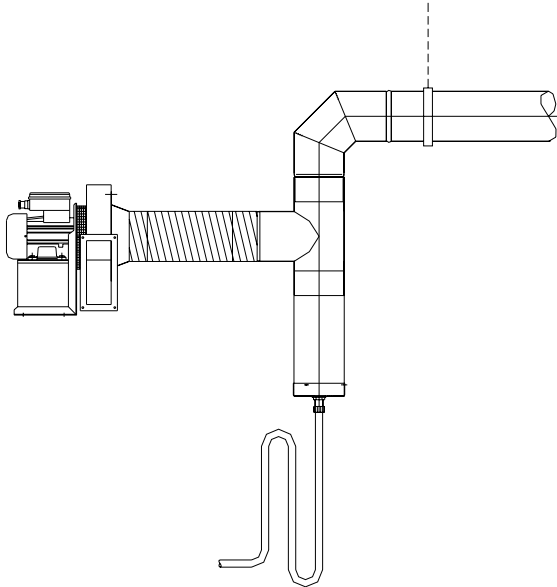
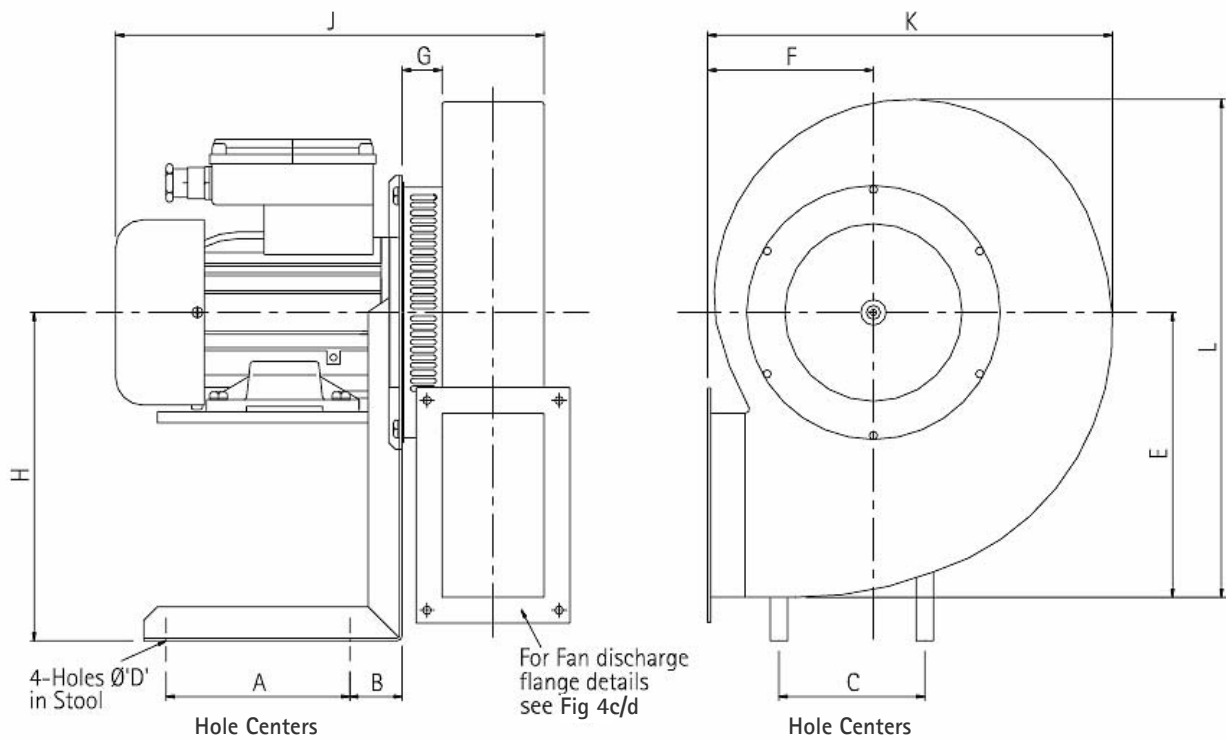

Figure 4h. Typical Low Fan Arrangement

Figure 5. Vacuum fan mounting details (Type 'O' fan illustrated)



Fan	Type O	Type 2
A	124	80
B	38	35
C	175	174
D	7.1	7
E	209	125
F	153	100
G	42	25
H	239	120
J	340	210
K	332	205
L	363	215
Power (watts)	550	120
Running Current (amps)	2.6	0.8
Voltage	230V 1ph	230V 1ph

Figure 6. Typical Herringbone system

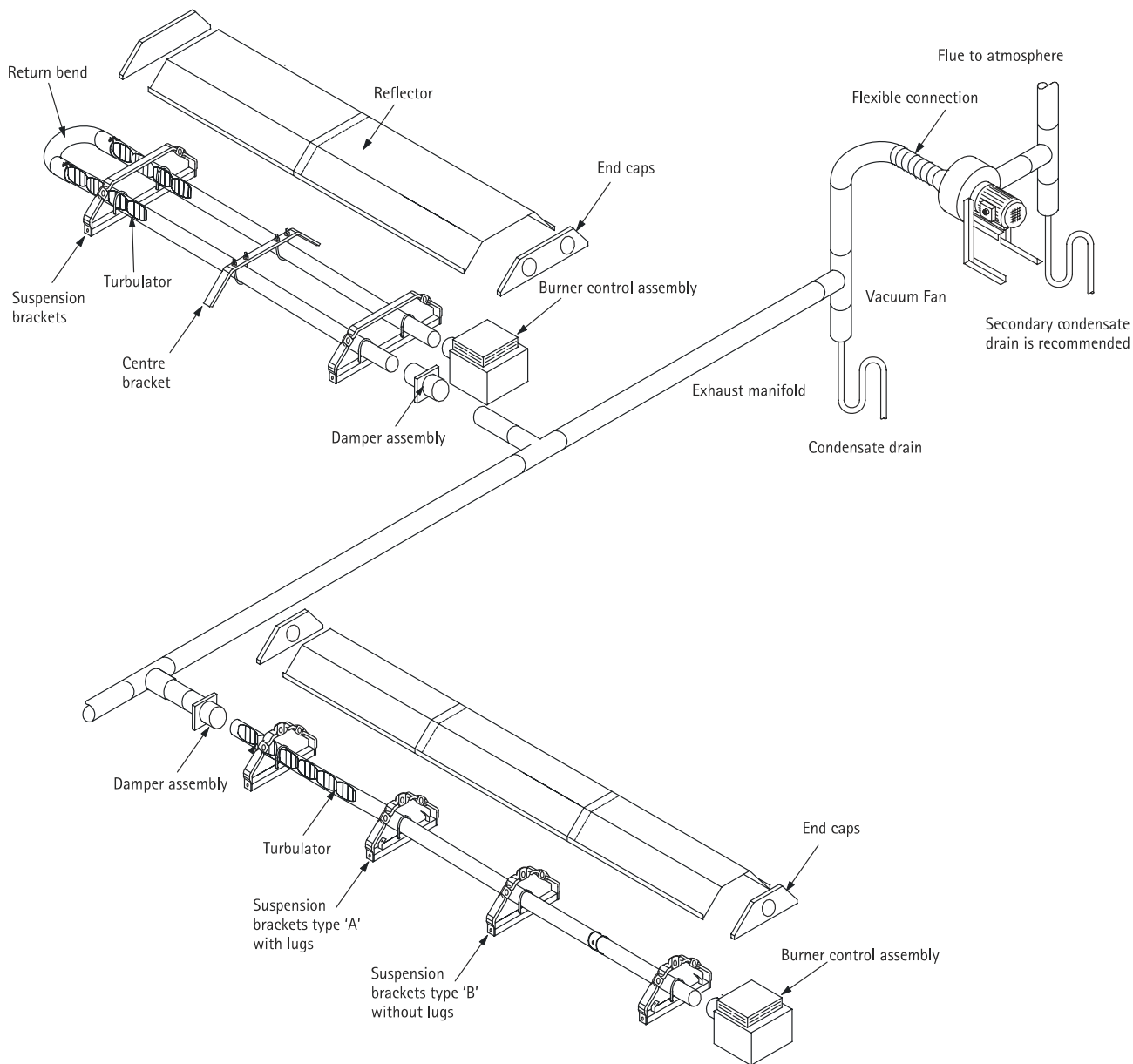

Dos and don'ts of herringbone system

Dos and don'ts of herringbone system	Don'ts
Check design pressure drop.	Run drains in copper pipe as it will corrode.
Check for corrosive industrial process in proposed building - e.g. cleaning, electroplating, printers using sugar powder etc.	Install system with extra 90° bends without asking AmbiRad if the system will operating correctly.
Drain all flue ducts and seal all joints.	Install flue vertical without firstly fitting a drain point at it's lowest level.
Secure joints with pop rivets as well as sealing compound (refer to assembly instructions).	Fit fan with outlet vertical or with top horizontal discharge.
Fit drain traps before and after fans (see figs 4).	Fit damper upside down or on it's side.
Fit expansion joints before fan and at intermediate points on the herringbone system.	Fit damper wrong way round.
Run drains in galvanised steel or plastic pipes.	
Follow guide to combined flue heating system.	

1.6 Clearance to Combustibles.

 The minimum clearances to combustible materials are given in the tables below. These minimum distances **MUST** be adhered to at all times.

Figure 7.a Diagram illustrating the clearance to combustibles (U tube shown)



VSUT / VSAUT		15/20	25/30	35/40	45/50
Above Reflector (VSUT/ONLY)	A	180	180	180	180
Above Reflector (VSAUT ONLY)	A1	280	280	280	280
Above Burner / Heater Outlet	B	500	500	500	500
To the Sides	C	900	1000	1100	1100
Below Tubes	D	1500	1700	2100	2100
Horizontally from Heater Outlet (UNFLUED)	E	1200	1200	1200	1200
End Wall (VSUT ONLY)	F	500	500	500	500

Figure 7.b Diagram illustrating the clearance to combustibles (VSLF shown)

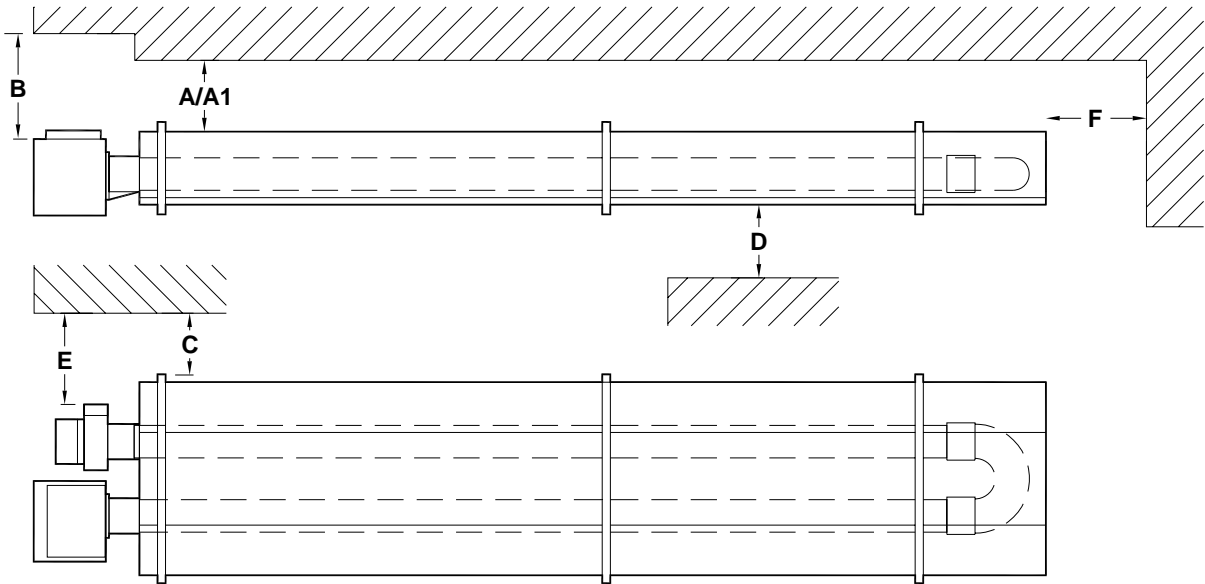
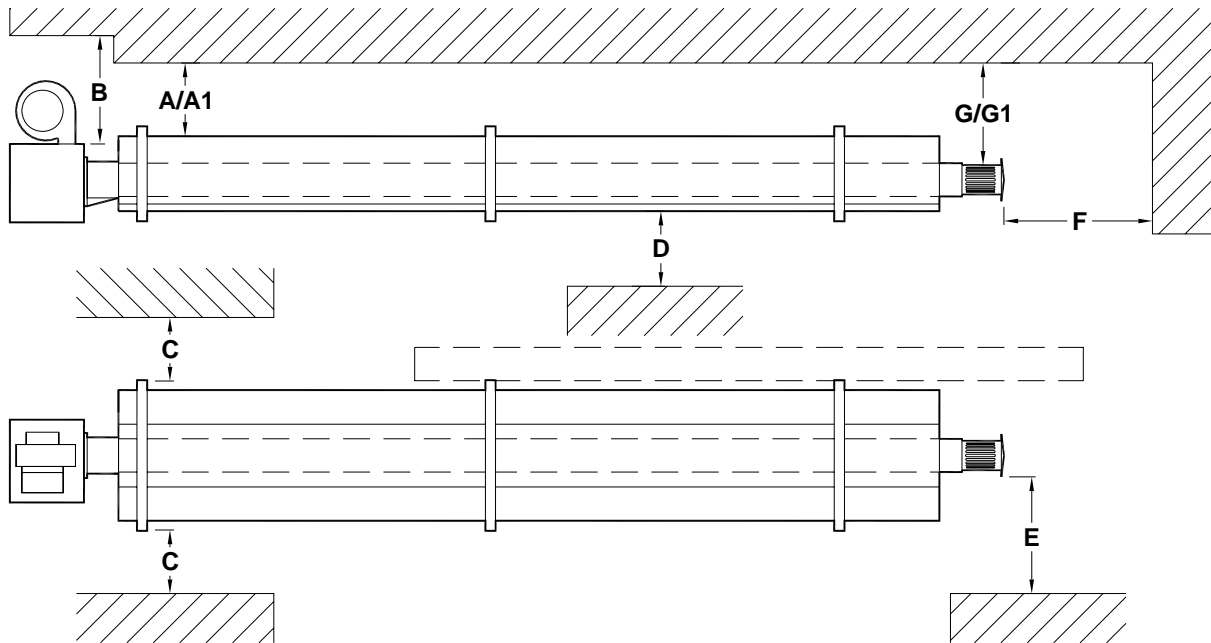

VS(A)LI; VS(A)LF; VS(A)LH; VS(A)DL		15/20	25/30	35/40	45/50
Above Reflector (VSLI/LF/LH/DL ONLY)	A	150	150	150	150
Above Reflector (VSALI/LF/LH/DL ONLY)	A1	280	280	280	280
Above Burner	B	500	500	500	500
To the Sides	C	750	750	750	750
Below Tubes	D	1500	1700	2100	2100
Horizontally from Heater Outlet (UNFLUED)	E	1200	1200	1200	1200
End Wall	F	500	500	500	500
Above Heater Outlet (FLUED)	G	150	150	150	150
Above Heater Outlet (UNFLUED)	G1	500	500	550	550

1.7 Gas Connection and Supply

! Before installation, check that the local distribution conditions, nature of gas and pressure, and adjustment of the appliance are compatible.

A competent or qualified engineer is required to either install a new gas meter to the service pipe or to check that the existing meter is adequate to deal with the rate of gas supply required. Installation pipes should be fitted in accordance with BS 6896:2005, so that the supply pressure, as stated in Table 4 will be achieved. It is the responsibility of the competent engineer to ensure that other relevant Standards and Codes of Practice are complied with in the country of installation. Pipes of smaller size than the heater inlet gas connection must not be used. The complete installation must be tested for soundness as described in the country of installation.

! The gas union service cock MUST be fitted in the gas supply close to the heater, but not onto the burner itself.

i Take care when making a gas connection

to the heater not to apply excessive turning force to the internal controls.

A flexible hose is installed to allow safe linear expansion of the heater without creating undue stress on the gas supply pipe work. It is therefore important that a tested and certified hose assembly made to ISO 10380 2003, supplied with ½" BSP female cone seat adapters, is installed as per these instructions.

It is also important to ensure that expansion is taken up in the body of the flexible hose, and not on its attachment to the pipe work. The cone seat adapter supplied on one end of the flexible gas hose provides a 'swivel' action, and must be fitted on the burner using a ½" BSP barrel nipple to provide ease of disconnection for future servicing. This assumes that the heater and fixed gas supply to the isolating valve have been installed.

i The installation layout described below is the only method recommended by the institute of gas engineers, the hose manufacturer, and AmbiRad and must only be carried out by a qualified/competent gas engineer.

Figure 8. Correct Installation of Flexible Gas Connection

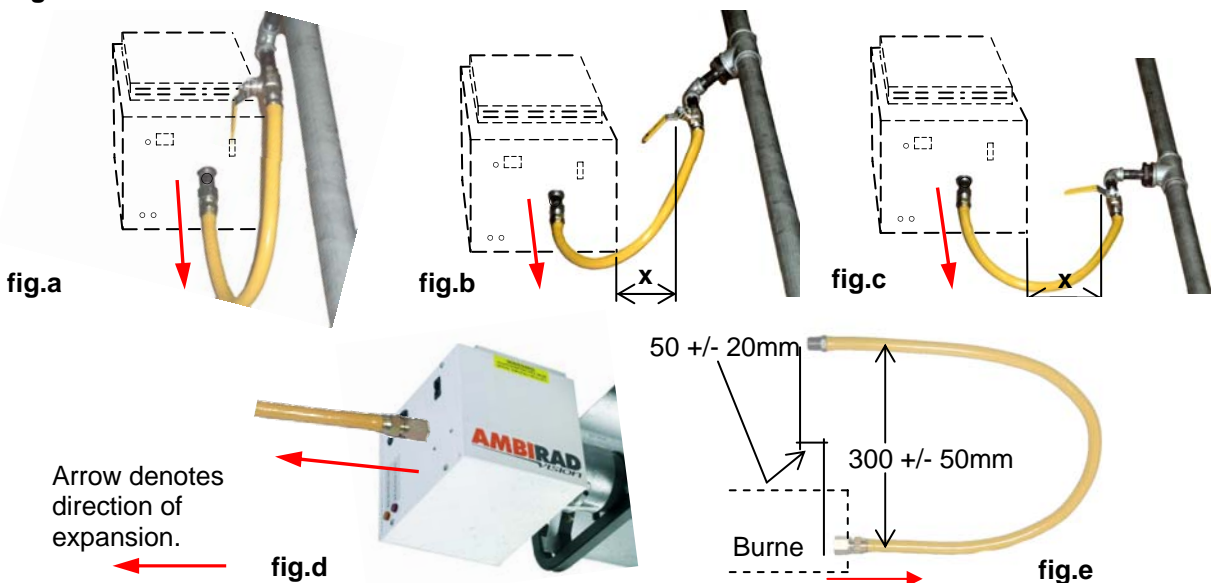

Depending on the specific installation, the flexible gas hose may be routed to the gas cock at any of the following angles in relation to the burner:

Vertical (fig.a)

45° angle (fig.b)

90° angle (fig.c)

Any other position in between these angles is acceptable.

! A clearance distance 'x' of min 200mm must be observed to allow side door access .

Care must be taken to observe the minimum pipe bend diameter (minimum 250mm, maximum 350mm) & pipe expansion distance (minimum 30mm, maximum 70mm) as shown in fig.e.

i Maximum bend diameter for the 1000mm hose is 450mm.

i The correct installation as shown will allow for approx 100mm of movement due to expansion.

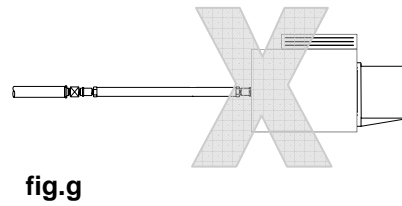
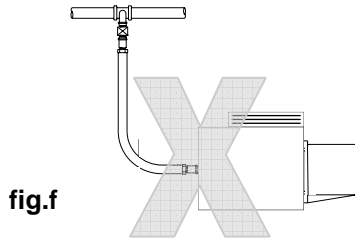

The methods shown in fig.f and fig.g are unacceptable, due to undue stress on the hose & fittings.

Table 4 Gas Supply Pressures

Gas Category	I2H
Gas Type	Natural Gas (G20)
Max Supply Pressure (mbar)	25
Min Supply Pressure (mbar)	17
Nominal Pressure (mbar)	20
Gas Supply	Connection R½ ½in BSP Internal Thread

1.8 Electrical Connections

This appliance must be earthed.
 Supply 230V 50Hz single phase.
 Standard heater 116W. Herringbone 16W.
 Current rating 0.55 amp max (inductive).
 Fuse: external 3 amp.

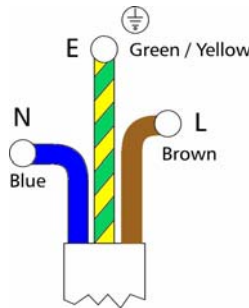

and comply with BS 6500:2000. The wires in the mains lead are coloured in accordance with the following code: Green & Yellow Earth; Blue Neutral; Brown Live

All electrical work should be carried out to IEE standards by a competent electrician. The electrical connection to the heater is made by means of a three pin plug-in power connector. Live, neutral and earth connections should be made via a flexible supply cable to the power connector and routed clear of the heater or tubes.

It is recommended the heater or group of heaters are controlled by thermostats, a time switch and if required manual control switches and a frost thermostat.

 We recommend use of AmbiRad approved controls. Please refer to control manual for siting and installation details. Where alternative manufactures controls are used, please refer to their instructions for their siting and installation details.

The flexible supply cables should be of 0.5mm²

Figure 9.a Typical VSUT/VSAUT Wiring Connections

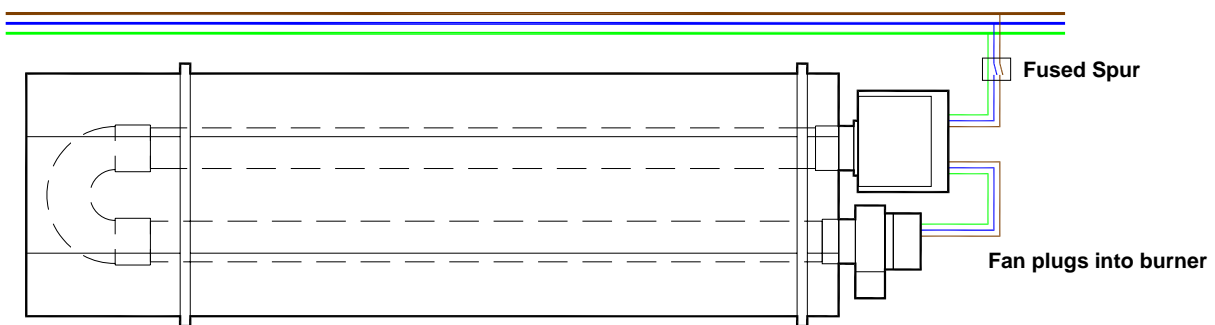

Figure 9.b Typical VSLF/VSALF Wiring Connections

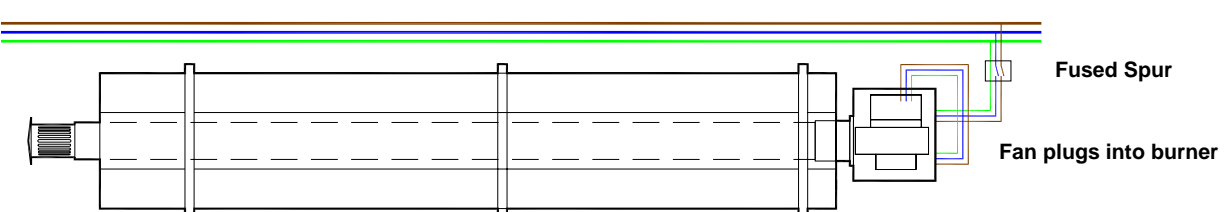

Figure 9.c Typical VSLI/VSALI Wiring Connections

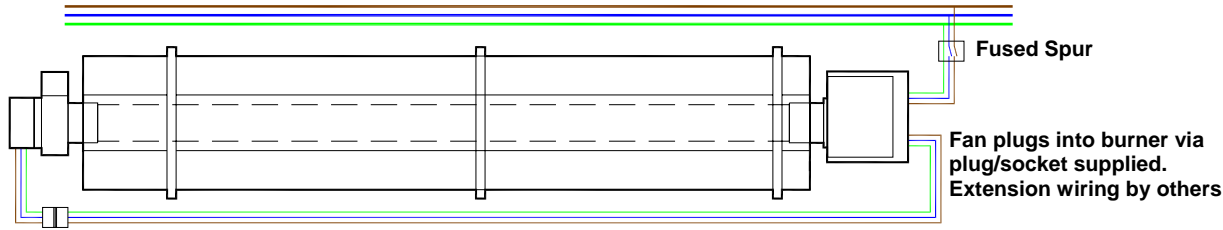

Figure 9.d Typical VSDL Wiring Connections

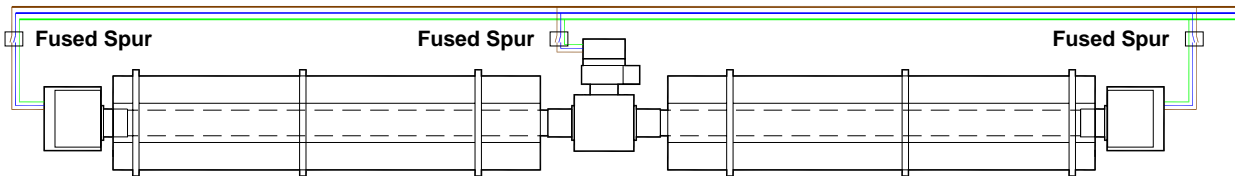

Figure 10. Internal Burner Wiring Diagram.

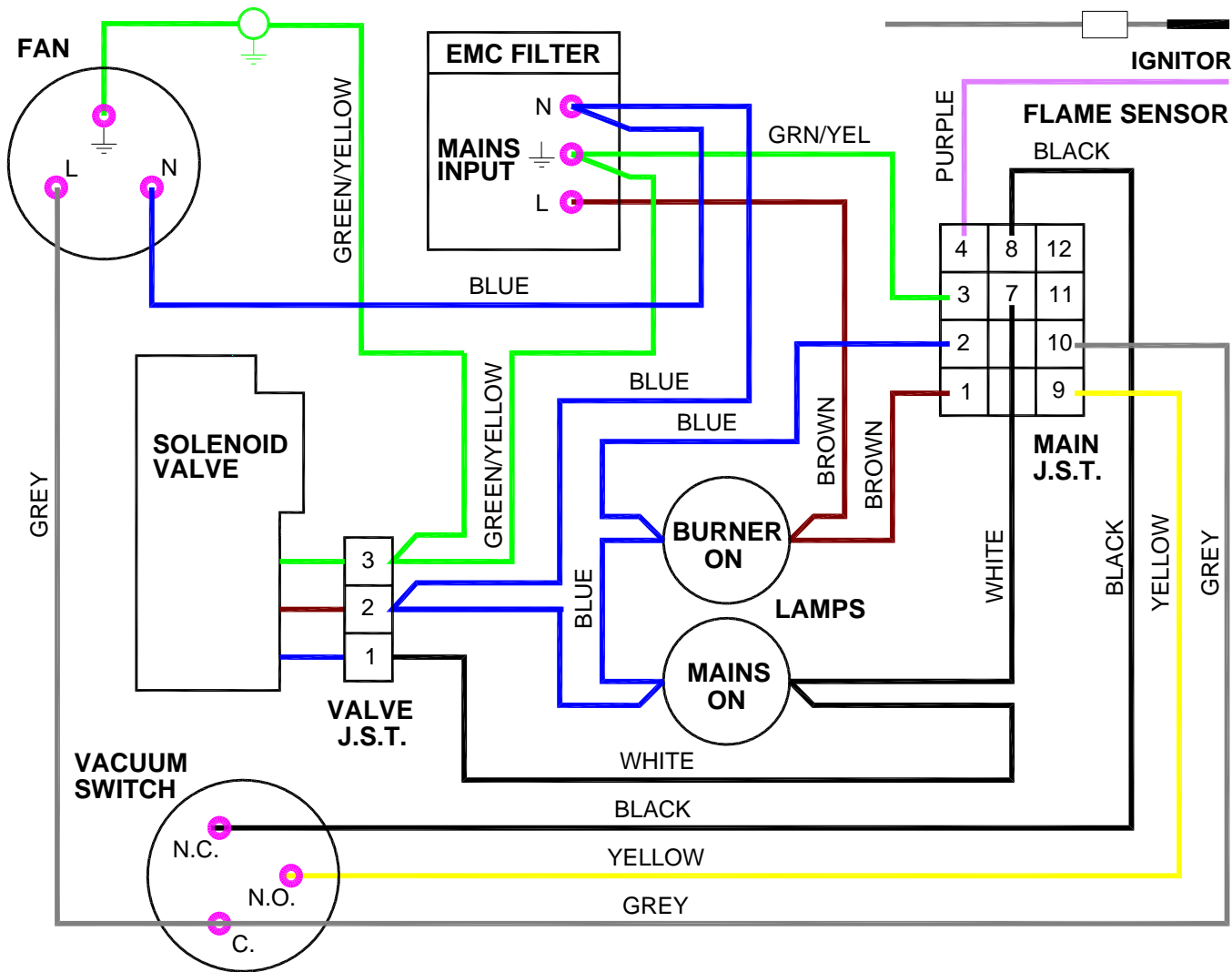
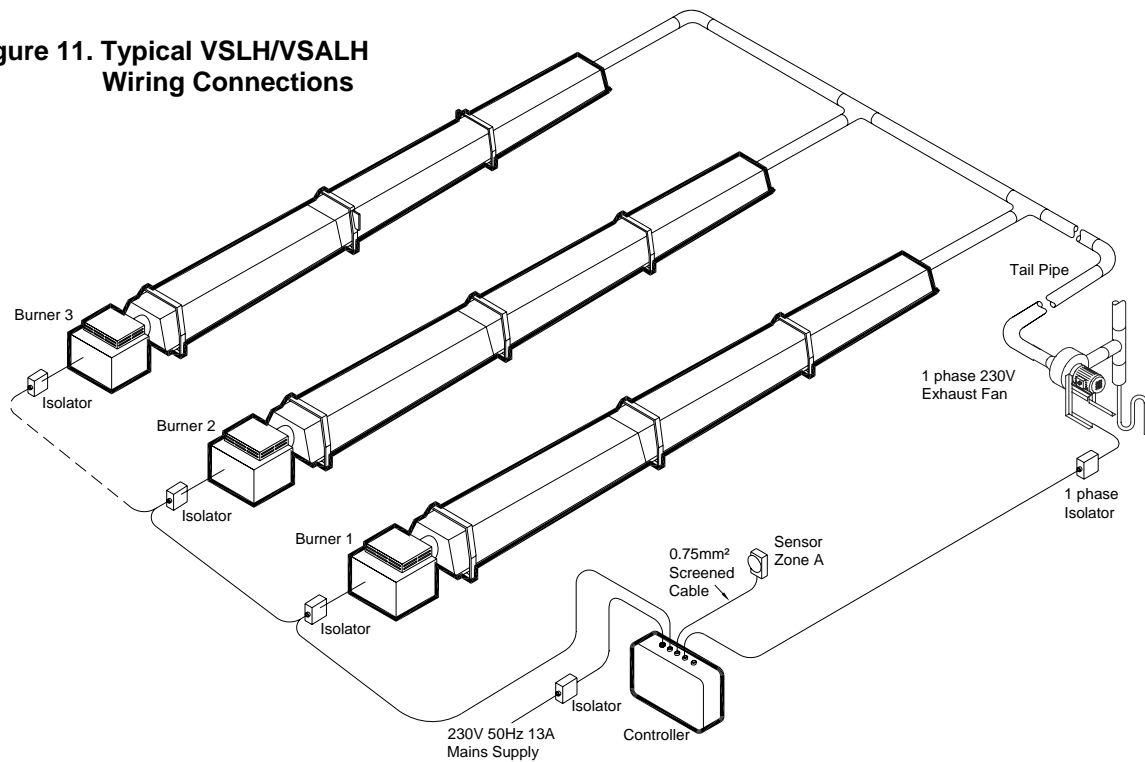

Figure 11. Typical VSLH/V SALH Wiring Connections



1.9 Ventilation Requirements

AmbiRad tube heaters can be operated as flued or unflued appliances in accordance with the relevant national requirements in the country of installation.

1.9.1 Unflued Radiant Heater

Radiant tube heaters can be operated as unflued appliances so that the concentration of Carbon Dioxide (CO₂) at positions where the air will be inhaled does not exceed 0.28%. BS EN 13410:2001 is a guide to achieving this requirement.

If the building air change rate exceeds 1.5 per hour or if the heat input is less than 5W/m³, no additional ventilation is required.

In addition to the ventilation requirements, consideration needs to be given to the possibility of condensation forming on cold surfaces.

It should be noted that the clearance distance around the burner increases when the unit is operated unflued (see section 1.6). It should be ensured that the combustion gases do not impinge on any combustible materials.

Mechanical Ventilation

Mechanical ventilation must be installed to meet a minimum of 1.5 air changes per hour using appropriately sized fans and interlocked with the heaters.

Natural Ventilation

BS EN 13410:2001 should be used to size air

vents to provide adequate ventilation, an example of this calculation is given below:

Site Details:

20°C Internal Operating Temperature
0°C Outside Air Temperature
5m between high and low level vents

Following the sizing procedure in BS EN 13410:2001 gives an air exit velocity of 1.6m/s. This equates to a free area vent at both high level and low level of 17.36cm²/kW free area.

1.9.2 Flued Radiant Heater

In buildings having an air change rate of less than 0.5 per hour, additional mechanical or natural ventilation is required. For detailed information, please see BS6896:2005 section 5.2.2.2.1

Mechanical Ventilation

Mechanical ventilation must be installed to meet a minimum of 0.5 air changes per hour using appropriately sized fans and interlocked with the heaters.

Natural Ventilation

Low level ventilation openings with a free area of at least 2cm²/kW shall be provided. See section 5.2.2.2.2.1.

1.10 Flue and Combustion Air Inlet - Options

Induced Burners without Heat Exchangers
Please refer to Figure 12 for options.

Figure 12. Flue Attachment Induced Burners (VSUT or VSAUT)

For non-flued installations, delete items A and B and rotate fan outlet to the HORIZONTAL position away from the burner.

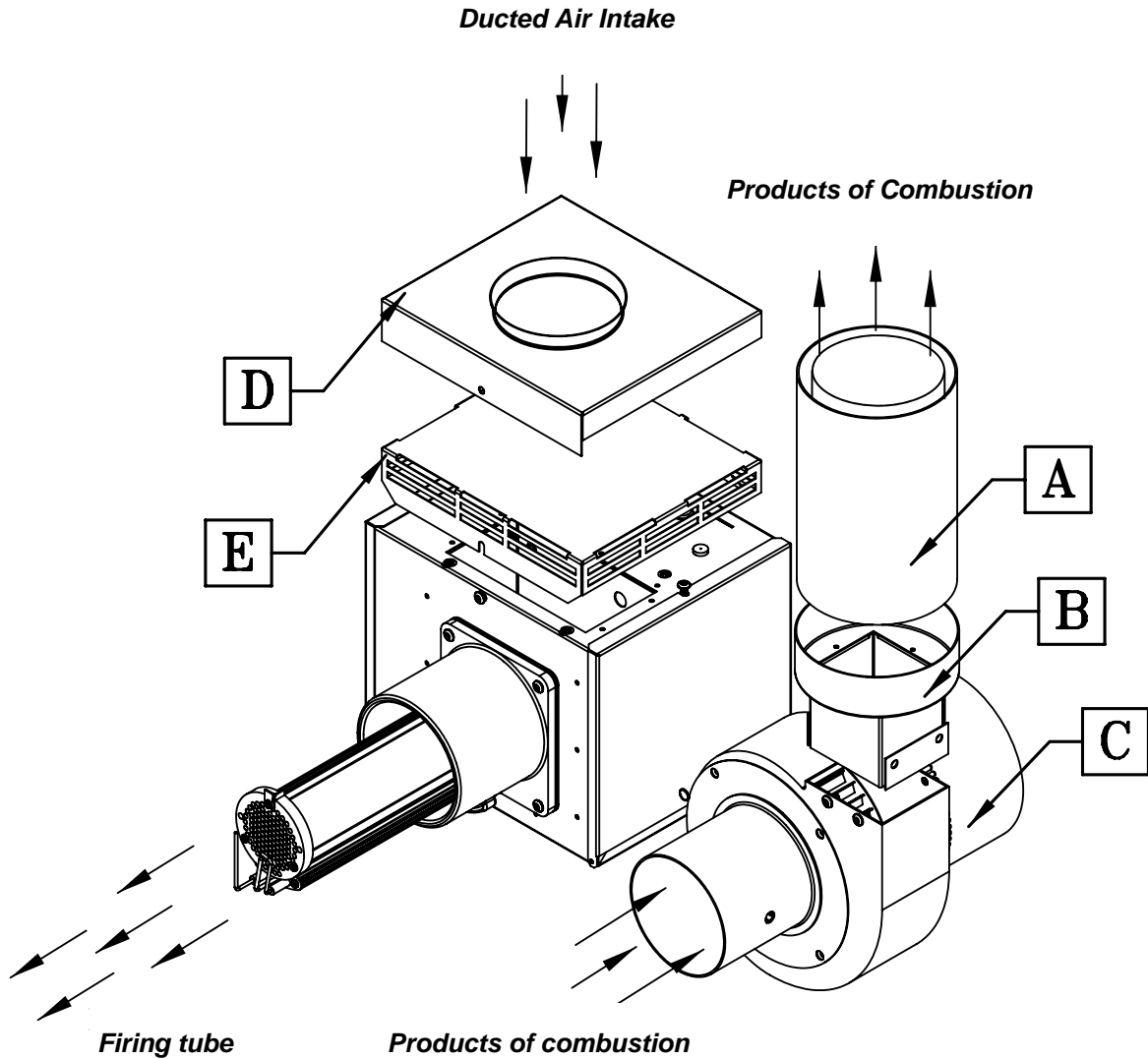

! if heaters are installed with no flue the ventilation instructions detailed in section 1.9 must be applied.

! Ducted air must be used in locations where there is airborne dust or where there is a polluted atmosphere e.g. Chlorinated Vapours.

i Maximum length = 9m
 Minimum diameter = 100mm
 Maximum no of bends = 2

A	127mm (5ins) Twin Wall Flue Pipe
B	Fan Adaptor
C	2501/2507 or 2560 Fan
D	Optional Ducted Air Intake. (see notes)
E	Standard Air Intake (supplied as standard)

Figure 13. End Attachments Forced Burners (VSLF or VSALF)

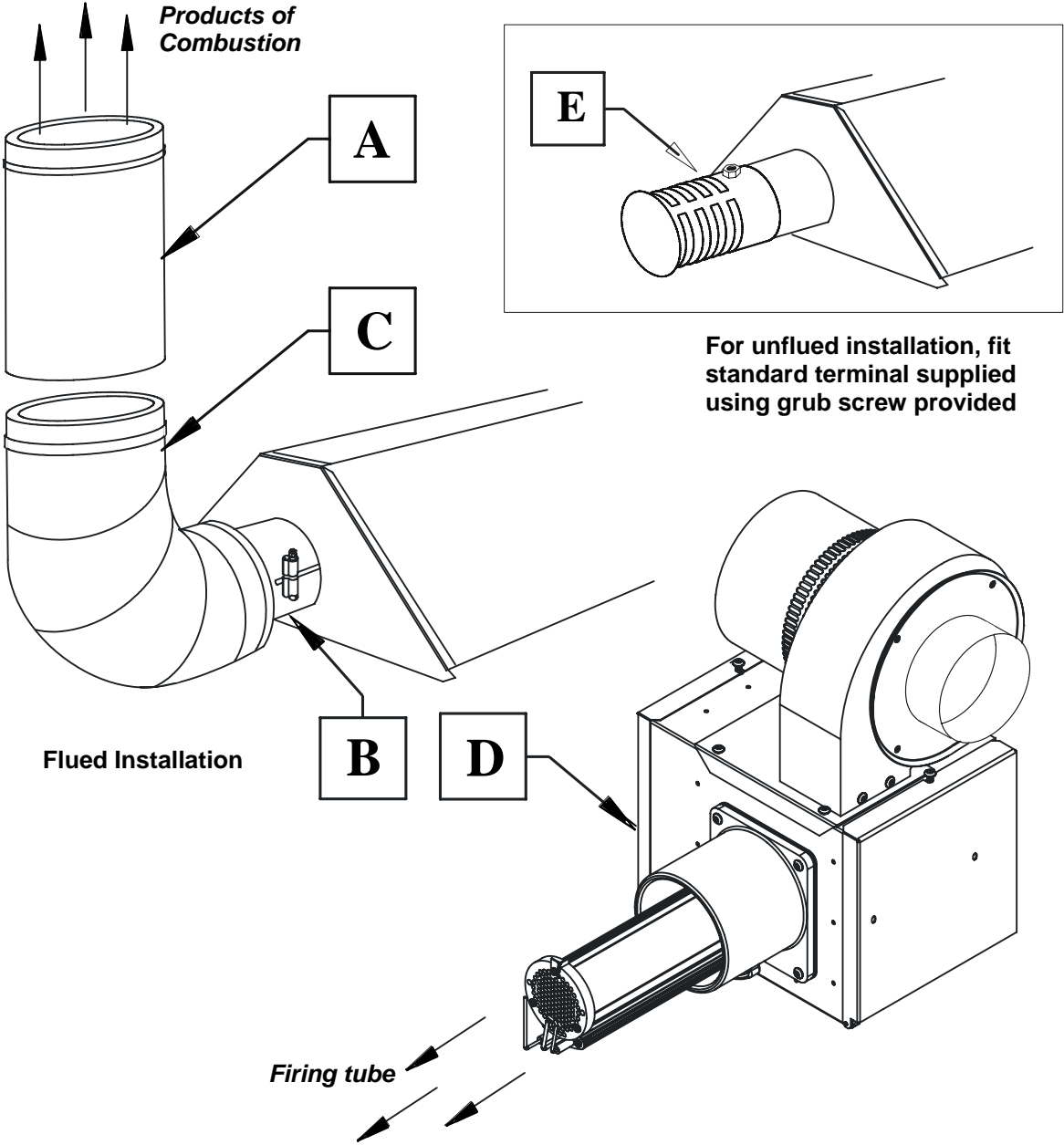

! if heaters are installed with no flue the ventilation instructions detailed in section 1.9 must be applied.

! Ducted air must be used in locations where there is airborne dust or where there is a polluted atmosphere e.g. Chlorinated Vapours.

i Maximum length = 9m
 Minimum diameter = 100mm
 Maximum no of bends = 2

A	127mm (5ins) Twin Wall Flue Pipe
B	Tube to Flue Adaptor
C	Flue Bend
D	Forced Burner
E	Standard end terminal (unflued)

1.11 Table 5 - Technical Details. All heaters to run on **Natural Gas (G20)**

		No of Injectors		1					
		Gas Connection		½ in BSP Internal thread					
		Flue Nominal Bore mm (in)		125 (5)					
		Unitary Fan Motor Details		230 volt 1 phase 50Hz					
Heater Model	Heat Input kW		Gas Flowrate (m³/hr)	Injector Pressure (mbar)	Injector Size (mm)	Size (h x l x w)	Weight (Kg)	Fan Rating (A)	Fan Type
	Gross	Nett							
VS(A)15UT4	15.8	14.2	1.5	11.1	1.3	260x2219x670	41	0.5	2501
VS(A)15UT	15.0	13.5	1.4	10.7	1.3	240x3417x500	43	0.5	2501
VS(A)20UT	19.5	17.6	1.9	10.8	1.5	240x4142x500	50	0.5	2501
VS(A)25UT	23.5	21.2	2.3	8.0	1.8	240x5066x500	60	1.0	2507
VS(A)30UT	29.5	26.5	2.8	9.5	2.0	240x6029x500	70	1.0	2507
VS(A)35UT	36.0	32.4	3.4	9.7	2.3	260x5709x670	92	1.0	2507
VS(A)40UT	40.0	36.0	3.8	12.2	2.3	260x5709x670	92	1.0	2507
VS(A)45UT	44.0	39.6	4.2	8.9	2.9	260x7471x670	121	1.0	2507
VS(A)50UT	48.0	43.2	4.6	9.1	2.5	260x7471x670	121	0.5	2560
VS(A)15LF6	13.8	12.4	1.3	9.8	1.3	390x5984x315	43	0.5	2501
VS(A)15LF8	13.8	12.4	1.3	9.8	1.3	390x8022x315	53	0.5	2501
VS(A)20LF7	19.5	17.6	1.9	12.0	1.5	390x6992x315	49	1.0	2507
VS(A)20LF10-5	19.5	17.6	1.9	12.0	1.5	390x10662x315	72	1.0	2507
VS(A)25LF8	23.5	21.2	2.3	9.5	1.8	390x8022x315	53	0.5	2501
VS(A)25LF10-5	23.5	21.2	2.3	9.5	1.8	390x10662x315	72	0.5	2501
VS(A)30LF10-5	29.5	26.6	2.8	11.5	2.0	390x10662x315	72	1.0	2507
VS(A)30LF12-5	29.5	26.6	2.8	11.5	2.0	390x12652x315	84	1.0	2507
VS(A)35LF10-5	36.5	32.9	3.5	11.5	2.3	390x10892x470	103	0.5	2501
VS(A)35LF13-5	36.5	32.9	3.5	11.5	2.3	390x13492x470	126	0.5	2501
VS(A)40LF13-5	40.0	36.0	3.8	12.5	2.4	390x13492x470	126	1.0	2507
VS(A)40LF16	40.0	36.0	3.8	12.5	2.4	390x16092x470	147	1.0	2507
VS(A)45LF13-5	45.0	40.5	4.3	11.0	2.9	390x13492x470	126	1.0	2507
VS(A)45LF16	45.0	40.5	4.3	11.0	2.9	390x16092x470	147	1.0	2507
VS(A)50LF13-5	50.0	45.0	4.8	13.6	3.0	390x13492x470	126	1.0	2507
VS(A)50LF16	50.0	45.0	4.8	13.6	3.0	390x16092x470	147	1.0	2507
VS(A)15LI6	15.0	13.5	1.4	10.7	1.3	390x5879x315	43	0.5	2501
VS(A)15LI8	15.0	13.5	1.4	10.7	1.3	390x7917x315	53	0.5	2501
VS(A)20LI7	19.5	17.6	1.9	10.8	1.5	390x6907x315	49	0.5	2501
VS(A)20LI10-5	19.5	17.6	1.9	10.8	1.5	390x10537x315	72	0.5	2501
VS(A)25LI8	23.5	21.2	2.3	8.0	1.8	390x7917x315	53	0.5	2501
VS(A)25LI10-5	23.5	21.2	2.3	8.0	1.8	390x10537x315	72	0.5	2501
VS(A)30LI10-5	29.5	26.6	2.8	9.5	2.0	390x10537x315	72	1.0	2507
VS(A)30LI12-5	29.5	26.6	2.8	9.5	2.0	390x12567x315	84	1.0	2507
VS(A)35LI10-5	36.0	32.4	3.4	9.6	2.3	390x10787x470	103	1.0	2507
VS(A)35LI13-5	36.0	32.4	3.4	9.6	2.3	390x13387x470	126	1.0	2507
VS(A)40LI13-5	40.0	36.0	3.8	12.2	2.3	390x13387x470	126	1.0	2507
VS(A)40LI16	40.0	36.0	3.8	12.2	2.3	390x16006x470	147	1.0	2507
VS(A)45LI13-5	44.0	39.6	4.2	8.9	2.9	390x13387x470	126	1.0	2507
VS(A)45LI16	44.0	39.6	4.2	8.9	2.9	390x16006x470	147	1.0	2507
VS(A)50LI13-5	50.0	45.0	4.8	10.0	2.5	390x13387x470	126	0.5	2560
VS(A)50LI16	50.0	45.0	4.8	10.0	2.5	390x16006x470	147	1.0	2507

Table 6. Herringbone & DL Settings

Model	Cold HB Pressure		Hot HB Pressure	
	mm H ₂ O	mbar	mm H ₂ O	mbar
VS(A)15UH4	21.4	2.1	12.7	1.2
VS(A)15UH	21.4	2.1	16.3	1.6
VS(A)20UH	19.4	1.9	15.3	1.5
VS(A)25UH	24.5	2.4	20.4	2.0
VS(A)30UH	23.5	2.3	19.4	1.9
VS(A)35UH	25.5	2.5	15.3	1.5
VS(A)40UH	29.6	2.9	17.3	1.7
VS(A)45UH	30.6	3.0	19.4	1.9
VS(A)50UH	33.0	3.2	23.5	2.3
VS(A)15LH6/DL12	18.4	1.8	13.3	1.3
VS(A)15LH8/DL16	18.4	1.8	14.3	1.4
VS(A)20LH7/DL14	19.4	1.9	14.3	1.4
VS(A)20LH10-5/DL21	18.4	1.8	14.3	1.4
VS(A)25LH8/DL16	20.4	2.0	16.3	1.6
VS(A)25LH10-5/DL21	22.4	2.2	18.4	1.8
VS(A)30LH10-5/DL21	24.5	2.4	19.4	1.9
VS(A)30LH12-5/DL25	33.6	3.3	25.5	2.5
VS(A)35LH10-5/DL21	27.5	2.7	13.3	1.3
VS(A)35LH13-5/DL27	20.9	2.0	12.7	1.2
VS(A)40LH13-5/DL27	22.4	2.2	12.2	1.2
VS(A)40LH16/DL32	21.4	2.1	14.3	1.4
VS(A)45LH13-5/DL27	27.5	2.7	16.8	1.6
VS(A)45LH16/DL32	26.5	2.6	17.3	1.7
VS(A)50LH13-5/DL27	30.0	2.9	18.3	1.8
VS(A)50LH16/DL32	27.5	2.7	17.8	1.7

No of Injectors	1
Gas Connection	½ in BSP Internal thread
Flue Nominal Bore mm (in)	125 (5)

Heater Model	Gross	Nett	Gas Flowrate (m ³ /hr)	Injector Pressure (mbar)	Injector Size (mm)	Size (h x l x w)	Weight (Kg)
VS(A)15LH6	15.0	13.5	1.4	10.7	1.3	390x5725x315	42
VS(A)15LH8	15.0	13.5	1.4	10.7	1.3	390x7763x315	52
VS(A)20LH7	19.5	17.6	1.9	10.8	1.5	390x6733x315	48
VS(A)20LH10-5	19.5	17.6	1.9	10.8	1.5	390x10363x315	71
VS(A)25LH8	23.5	21.2	2.3	8.0	1.8	390x7763x315	52
VS(A)25LH10-5	23.5	21.2	2.3	8.0	1.8	390x10363x315	71
VS(A)30LH10-5	29.5	26.6	2.8	9.5	2.0	390x10363x315	71
VS(A)30LH12-5	29.5	26.6	2.8	9.5	2.0	390x12393x315	83
VS(A)35LH10-5	36.0	32.4	3.4	9.6	2.3	390x10633x470	101
VS(A)35LH13-5	36.0	32.4	3.4	9.6	2.3	390x13233x470	124
VS(A)40LH13-5	40.0	36.0	3.8	12.2	2.3	390x13233x470	124
VS(A)40LH16	40.0	36.0	3.8	12.2	2.3	390x15832x470	145
VS(A)45LH13-5	44.0	39.6	4.2	8.9	2.9	390x13233x470	124
VS(A)45LH16	44.0	39.6	4.2	8.9	2.9	390x15832x470	145
VS(A)50LH13-5	50.0	45.0	4.8	10.0	2.5	390x13233x470	124
VS(A)50LH16	50.0	45.0	4.8	10.0	2.5	390x15832x470	145

Table 7. Herringbone Vacuum Fan characteristics

Fan type		Type 'O'	Type '2'
Power	(W)	550	120
Running current (overload setting)	(A)	2.6	0.8
Phase		Single	Single
Voltage	(V)	230	230

Table 8. Flue details

Heater Model	Mass Flow Rate of Flue Gasses (kg/s)	Flue Pressure (Pa) Maximum Flue Resistance	Flue Gas Temp (°C)		
VS(A)15UT4	0.0110	15 - 31	200 - 250		
VS(A)15UT	0.0115				
VS(A)20UT	0.0117				
VS(A)25UT	0.0139				
VS(A)30UT	0.0171				
VS(A)35UT	0.0193				
VS(A)40UT	0.0210				
VS(A)45UT	0.0212				
VS(A)50UT	0.0261				
VS(A)15LI6	0.0098			19 - 30	210 - 270
VS(A)20LI7	0.0119				
VS(A)25LI8	0.0131				
VS(A)30LI10-5	0.0171				
VS(A)35LI10-5	0.0207				
VS(A)40LI13-5	0.0216				
VS(A)45LI13-5	0.0249				
VS(A)50LI13-5	0.0256				
VS(A)15LI8	0.0100	25 - 35	160 - 210		
VS(A)20LI10-5	0.0120				
VS(A)25LI10-5	0.0145				
VS(A)30LI12-5	0.0174				
VS(A)35LI13-5	0.0194				
VS(A)40LI16	0.0214				
VS(A)45LI16	0.0237				
VS(A)50LI16	0.0237				
VS(A)15LF6	0.0075			18 - 25	250 - 290
VS(A)20LF7	0.0106				
VS(A)25LF8	0.0127				
VS(A)30LF10-5	0.0130				
VS(A)35LF10-5	0.0157				
VS(A)40LF13-5	0.0168				
VS(A)45LF13-5	0.0189				
VS(A)50LF13-5	0.0206				
VS(A)15LF8	0.0077	20 - 30	180 - 240		
VS(A)20LF10-5	0.0105				
VS(A)25LF10-5	0.0126				
VS(A)30LF12-5	0.0136				
VS(A)35LF13-5	0.0161				
VS(A)40LF16	0.0167				
VS(A)45LF16	0.0190				
VS(A)50LF16	0.0207				

2. Assembly Instructions.

 **PLEASE READ** this section prior to assembly to familiarise yourself with the components and tools you require at the various stages of assembly. Carefully open the packaging and check the contents against the parts and check list.

The manufacturer reserves the right to alter specifications without prior notice.

 Please ensure that all packaging is disposed of in a safe environmentally friendly way.

 For your own safety we recommend the use of safety boots and leather faced gloves when handling sharp or heavy items. The use of protective eye wear is also recommended.

2.1 Tools Required.

The following tools and equipment are advisable to complete the tasks laid out in this manual.

 Suitable alternative tools may be used.



2.2 Assembly Notes.

 Please read these assembly notes in conjunction with the correct assembly drawings (figs 14 to 28).

2.2.1 Tubes

Identify and position tubes on trestles. For aesthetics it is advisable to position the tube seam and coupling fastener so that these cannot be seen from beneath the heater. Mark out the position of the bracket centres from the dimensions shown on the assembly drawings.

2.2.2 Turbulators (where fitted)

Insert turbulator(s) into tube(s) ensuring the correct length and quantity are inserted into their respective correctly identified tube(s) as detailed in the assembly drawings.

2.2.3 Brackets

There can be three types of brackets supplied with these heaters:

- Type 'A' are suspending brackets with reflector fixing points.
- Type 'B' are suspending brackets with no fixing points.
- Type 'C' is a centre bracket to retain the reflector. (certain models only)

Slide the bracket assemblies along to the tubes to the marked positions in their correct order as detailed in the assembly drawings. Tighten clamping 'U' bolt arrangement to tubes **ONLY WHERE STATED** on the assembly drawings.

2.2.3.1 Tube alignment sections

For VS(A)50UT Angle Mounted Installations ONLY. To allow for differential expansion of the tubes, a tube alignment assembly is fitted to the first bracket on the fan side radiant tube.

Position U bolt tube alignment sections over the tube and through bracket prior to clamping.

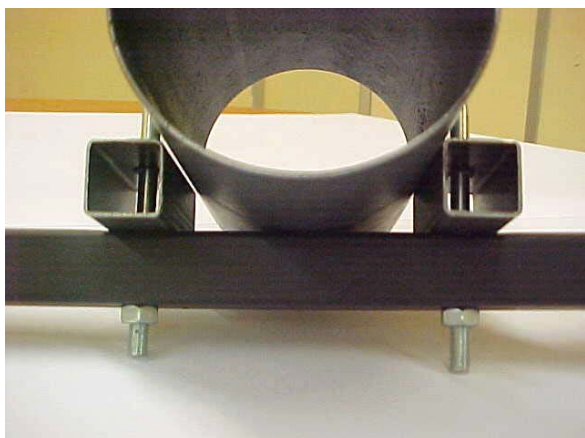

2.2.4 U Bend.

For VS(A) 'U' tube heaters only. Slide the 'U' bend onto the tube ends with the clamping bolts facing upwards until the predefined stop position. Tighten clamping bolt arrangement using 13mm socket and wrench.

2.2.5 Couplers.

For VS(A)LF, VS(A)LH, VS(A)LI and VS(A) 45/50UT tube heaters only. For joining radiant tubes, locate and position tube couplers at the end of the tubes so that the socket heads are facing outwards. Tighten clamping bolt arrangement to secure ensuring the bolts are not over tightened.

 *To avoid damaging the heater whilst installing we recommend the heater chassis be suspended prior to fitting reflectors.*

2.2.6 Reflectors.

After removing the protective plastic coating, slip the reflector through the brackets until the locating slots are aligned with the type A bracket fixing points.

Slide the next reflector through the brackets and overlap the existing reflector until the locating slots line up with the same bracket fixing points. Secure overlapped reflectors to bracket using M6 nuts, bolts and flat mud washers.

 All reflectors must be positioned/ attached to the brackets exactly as detailed in the assembly drawings.

2.2.7 End Caps.

On VSUT models only, position the end cap with no tube holes beneath the reflector profile at the U bend end with the end cap flanges facing inwards. Fasten to reflector using M5 pozi set pin and 'Z' clips. Position the end cap with tube holes beneath the reflector profile at the burner end with the end cap flanges facing inwards. Fasten to reflector using M5 pozi set pin and 'Z' clips.

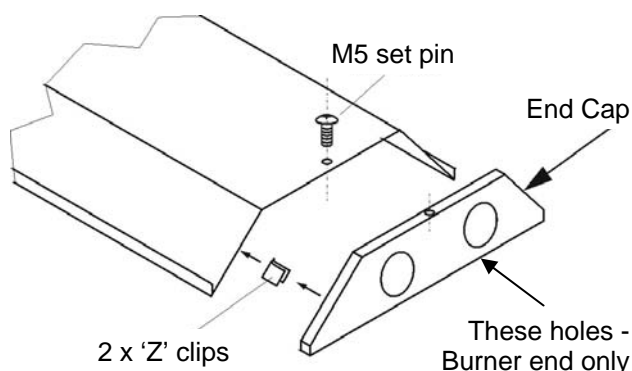

On VS(A)LF, VS(A)DL & VS(A)LH models only, position ONE end cap beneath the reflector profile at the open/fan/damper end with the end cap flanges facing inwards. Fasten to reflector using 'Z' clips. Position the other end cap beneath the reflector profile at the burner end with the end cap flanges facing inwards. Fasten to reflector using 'Z' clips.

2.2.8 Burner Assembly.

On VS(A)UT only, slide the burner assembly onto the **RIGHT HAND TUBE** when viewed from above, ensuring it is fully engaged. Secure with grub screws.

On VS(A)LF, VS(A)DL & VS(A)LH models only, slide the burner assembly onto the **inlet end of the tube** ensuring it is fully engaged. Secure with grub screws.

2.2.9 Fan Assembly.

On U Tube heaters only, slide fan onto the left hand tube ensuring it is fully engaged. The fan discharge should face vertically for individually flued or horizontally away from the burner if unflued.

2.2.10 Condensate Box Assembly.

On VS(A)DL models only, slide the condensate box flange onto the **outlet end of**

the tube ensuring it is fully engaged. Secure with grub screws.

2.2.11 HB Damper Assembly.

On VS(A)UH and VS(A)LH models only, slide the damper assembly flange onto the **outlet end of the tube** ensuring it is fully engaged. Secure with grub screws. Note: The damper assembly must be located with its damper blade vertical and left in the closed position. The manifold tube is to be sealed and secured (as described below) to the damper assembly.

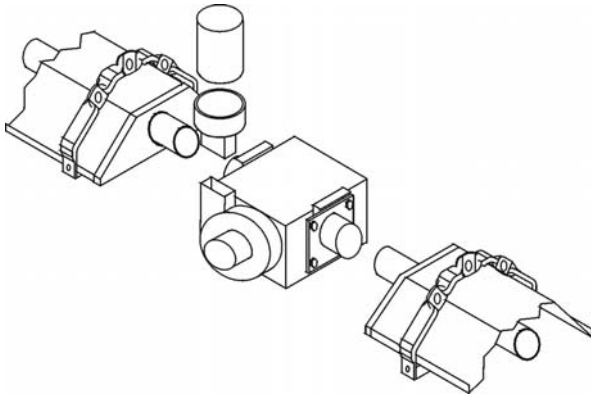

2.2.12 HB Manifold Assembly.

HB Models ONLY. After fixing the heaters in the desired position, the manifold system requires fitting.

After allowing for a minimum of 75mm (3in) of penetration of the fitting into the tube, cut the tubes to the lengths required and remove all burrs and wipe off any grease or oil with a clean rag.

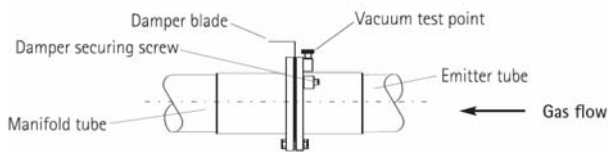

Method of jointing aluminium tube

Using the applicator gun exude 4mm diameter bead of high temperature silicon jointing compound externally round the end of the fitting and internally round the end of the tube.

Enter the fitting into the tube using a slight rotating movement to spread the jointing compound uniformly until a penetration of 75mm (3in) is achieved.

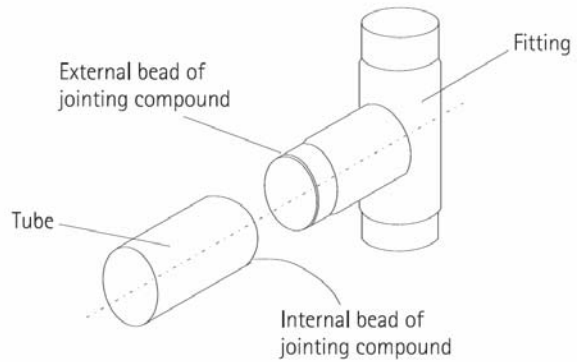

Note The silicon jointing compound remains workable after application for only 5 minutes.

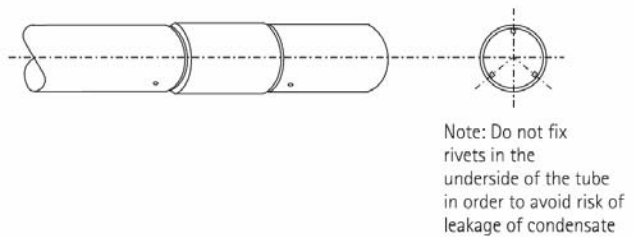

Secure the joint by drilling through the tube and fitting and fix with three pop rivets at 12 o'clock, 4 o'clock and 8 o'clock positions. 4.8mm (3/16in) diameter pop rivets are recommended.

2.2.13 Detailed Assembly Drawings

The following pages show the technical dimensional details of the VSUT/VSAUT, VSUH/VSAUH and VSLF/VSLH/VSA LH, VSDL/VSDLH range of heaters.

Please note the heater type, length and reference number from the delivery/advice note before identifying the correct model drawing.

Figure 14. Vision Heater Assembly: Models VS/VSA U tube 15kW. 100mm (4ins) Nominal Dia

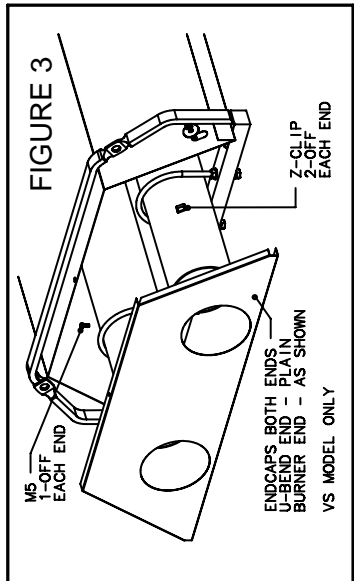
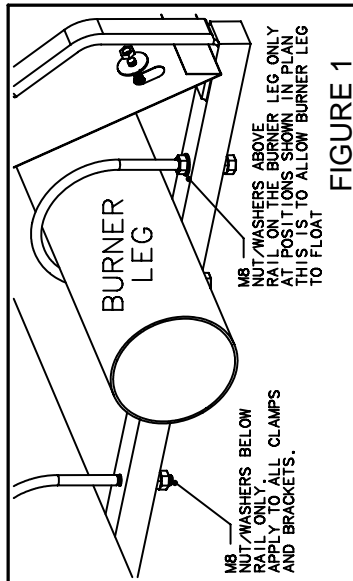
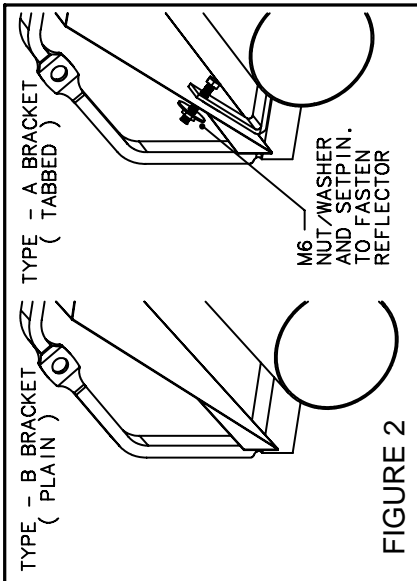
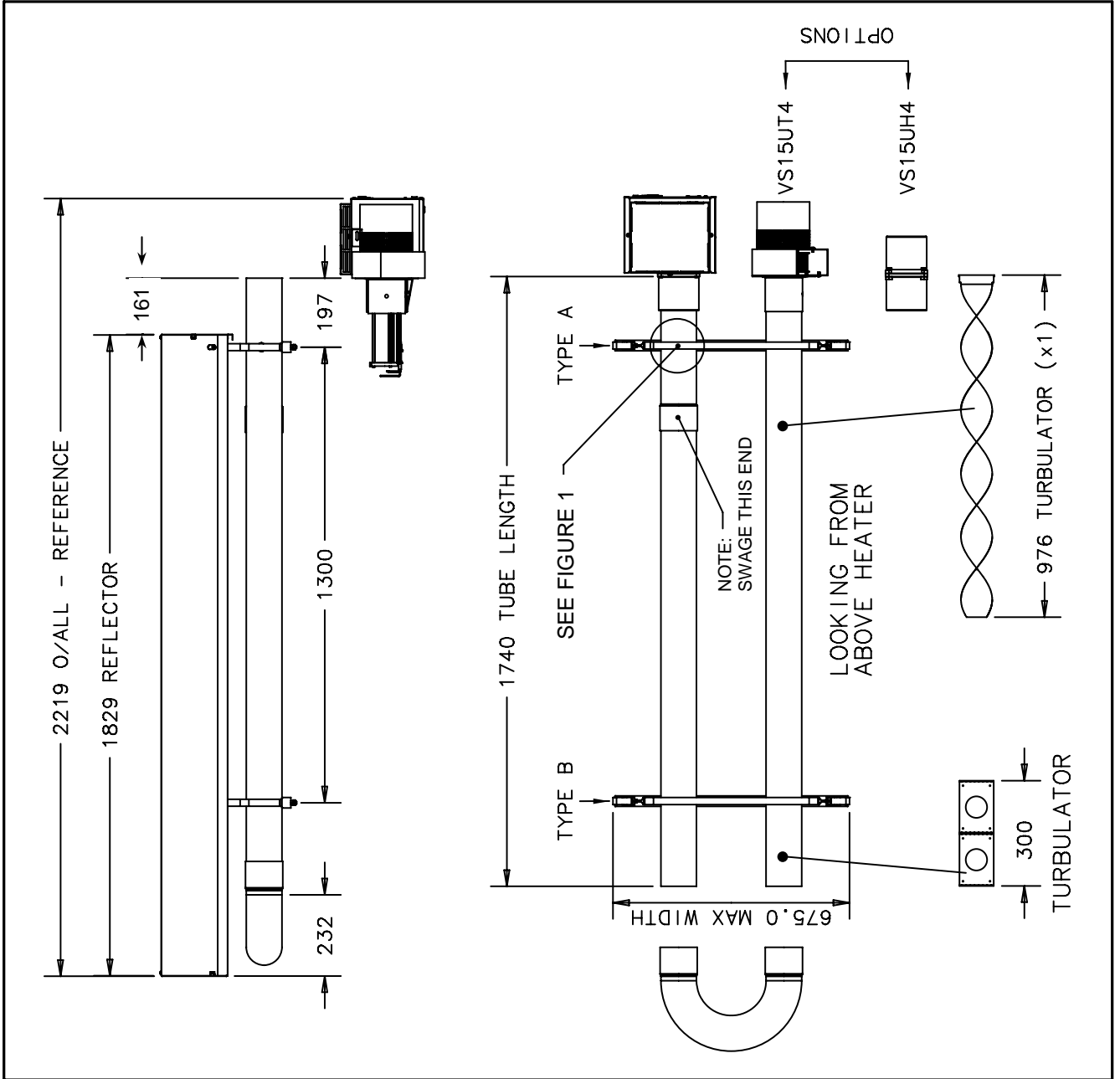

VISION U-TUBE HEATERS
VS15UT4
VS15UH4
NOTE :- VSA MODELS HAVE ALUMINISED REFLECTORS AND NO END CAPS. ALL OTHER MODEL DETAILS AS SHOWN.

Figure 15. Vision Heater Assembly: Models VS/VSA U tube 15kW.

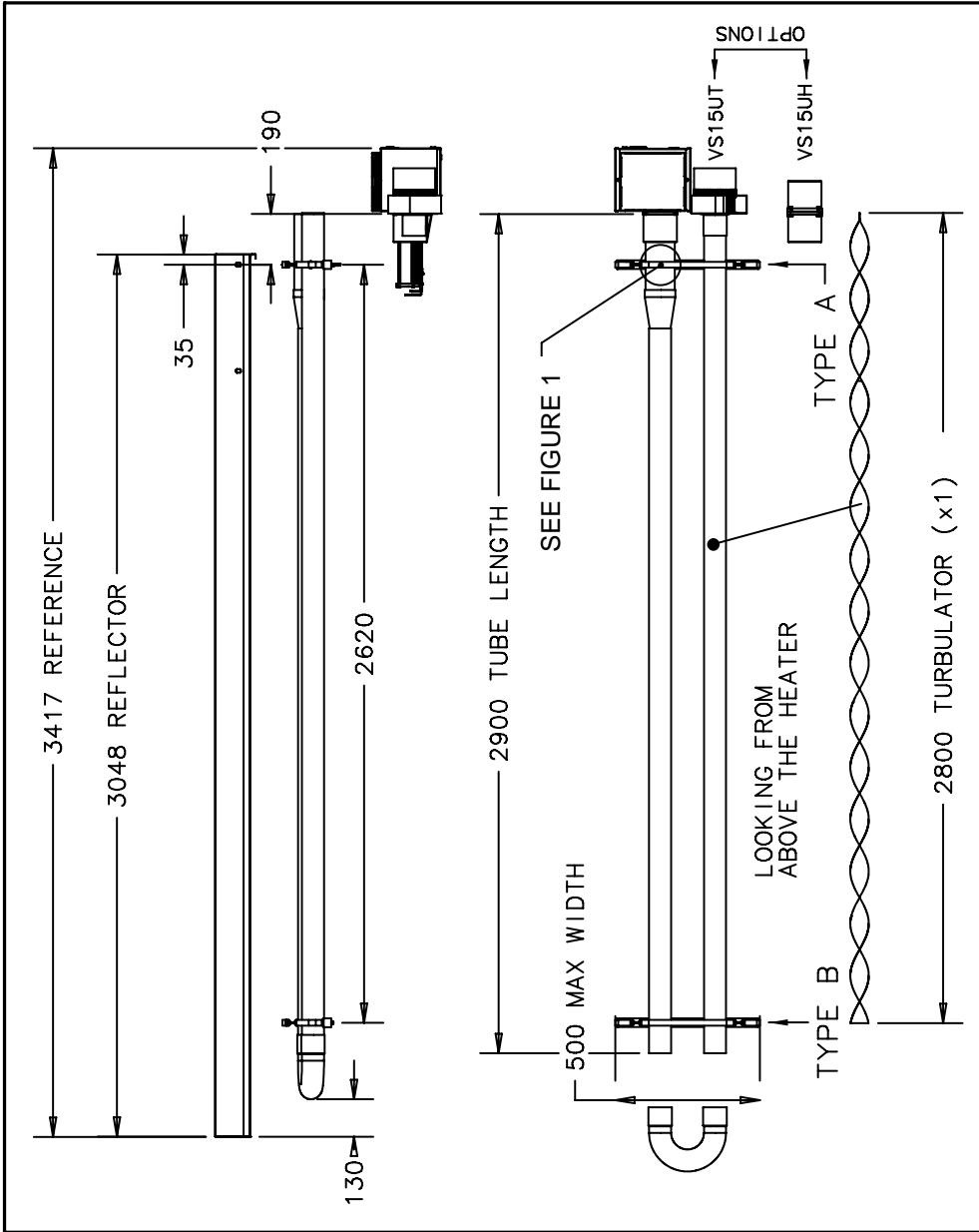

VISION U-TUBE HEATERS	
VS15UT	
VS15UH	
NOTE :- VSA MODELS HAVE ALUMINISED REFLECTORS AND NO END CAPS. ALL OTHER MODEL DETAILS AS SHOWN.	

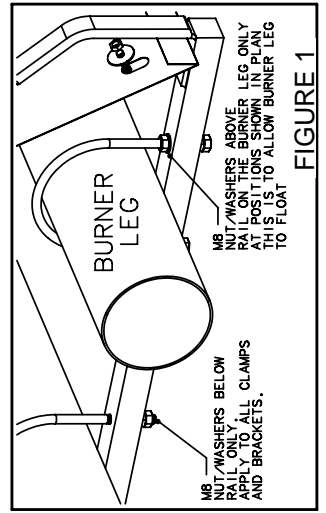

FIGURE 1

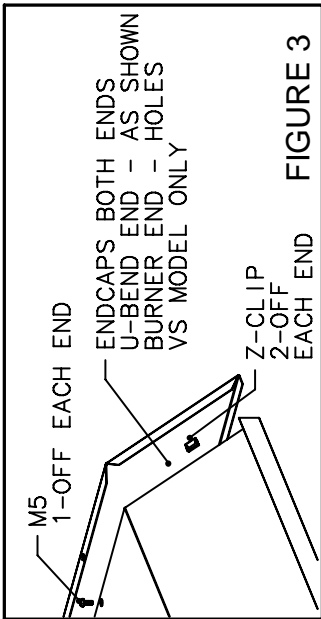

FIGURE 3

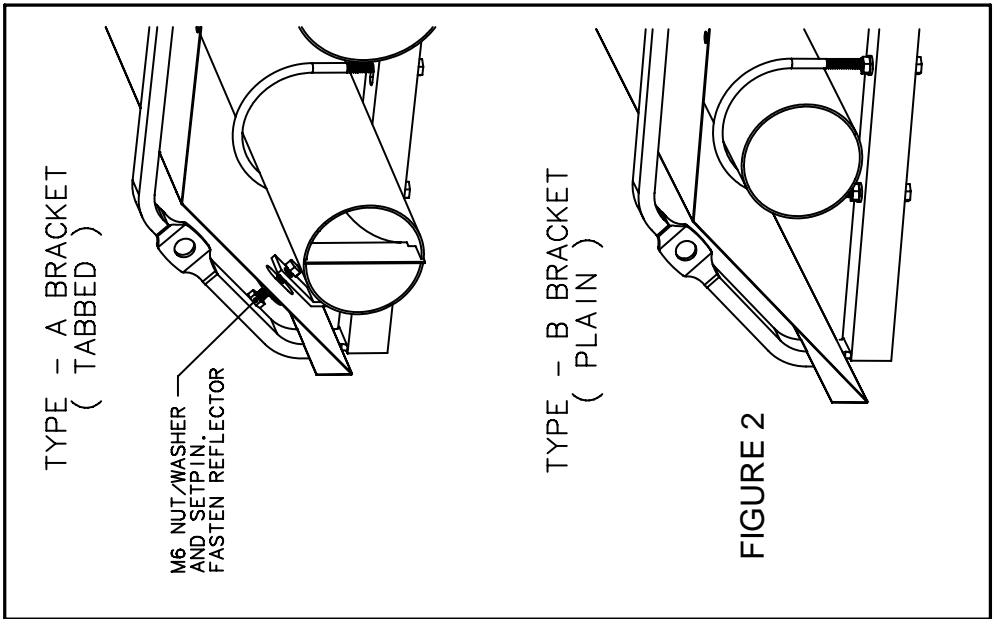
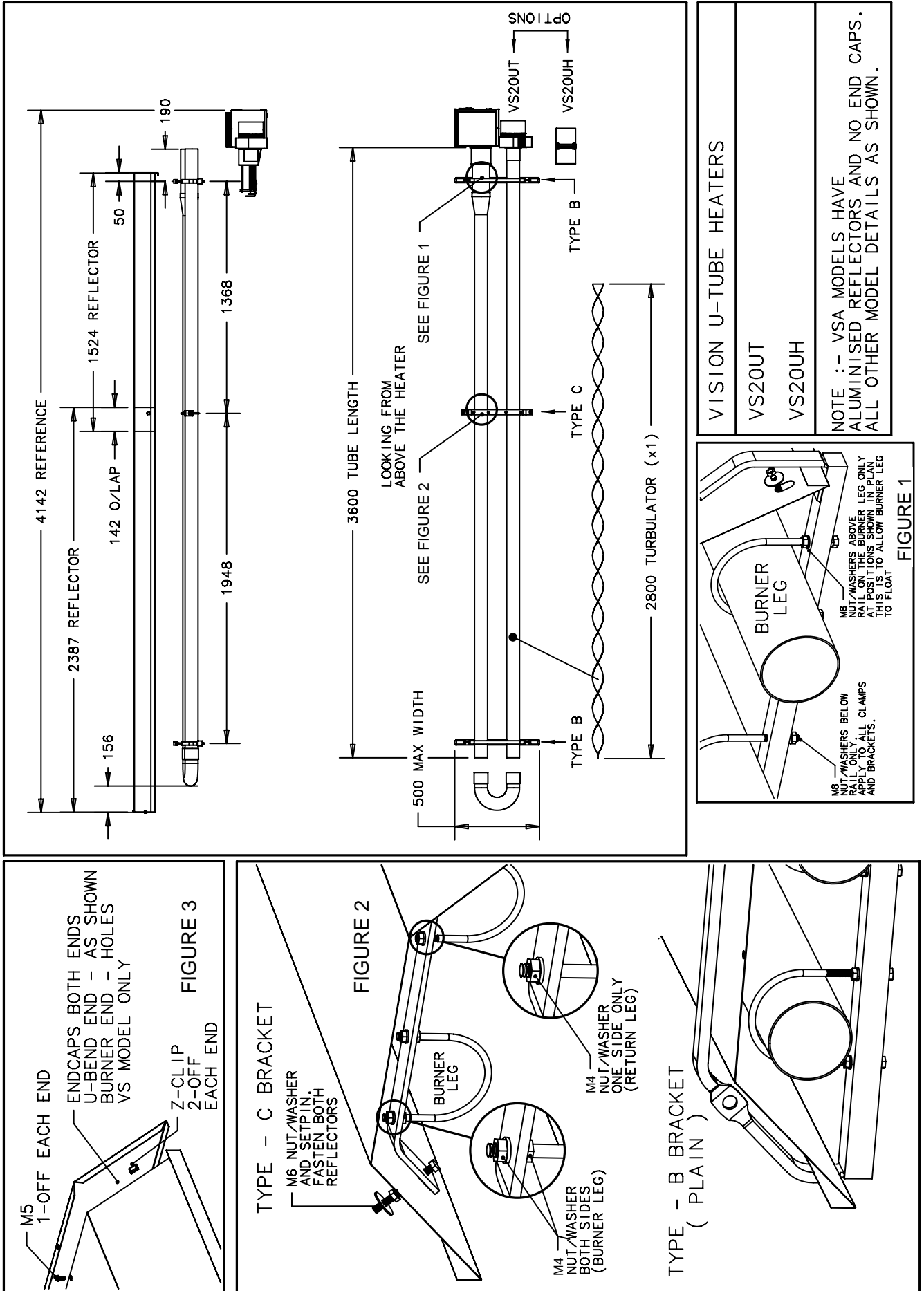

FIGURE 2

Figure 16. Vision Heater Assembly: Models VS/VSA U tube 20kW.



VISION U-TUBE HEATERS	
VS20UT	
VS20UH	
NOTE :- VSA MODELS HAVE ALUMINISED REFLECTORS AND NO END CAPS. ALL OTHER MODEL DETAILS AS SHOWN.	

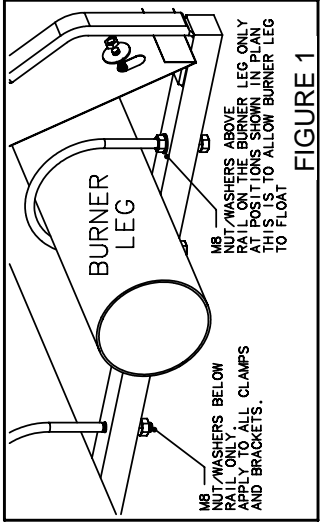
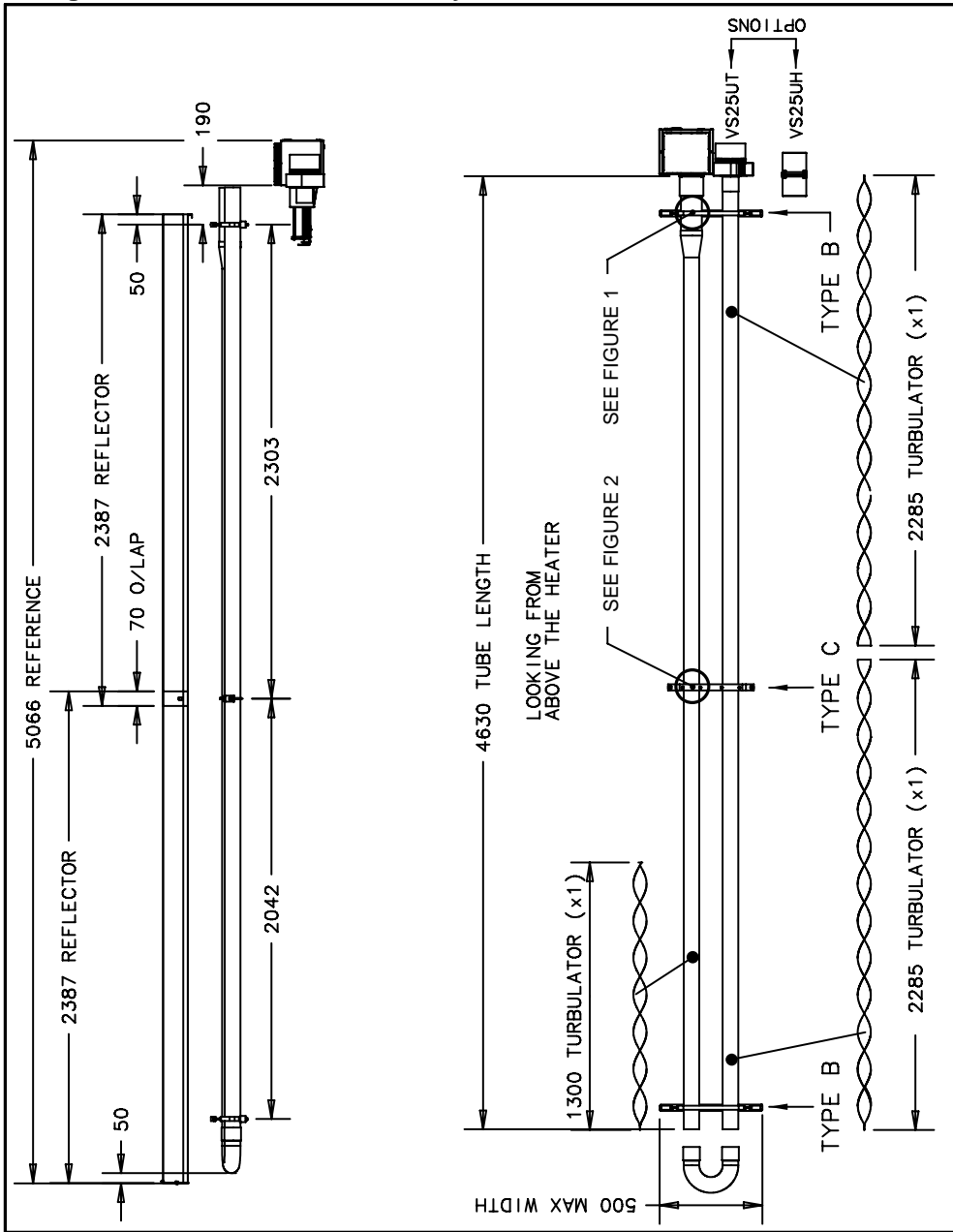

Figure 17. Vision Heater Assembly: Models VS/VSA U tube 25kW.



VISION U-TUBE HEATERS	
VS25UT	
VS25UH	

NOTE :- VSA MODELS HAVE ALUMINISED REFLECTORS AND NO END CAPS. ALL OTHER MODEL DETAILS AS SHOWN.

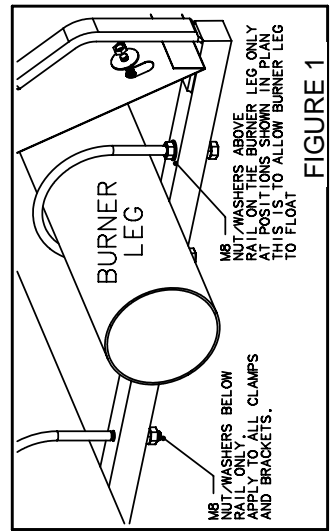

FIGURE 1

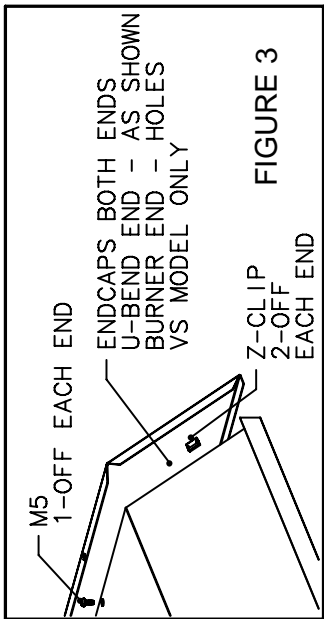

FIGURE 3

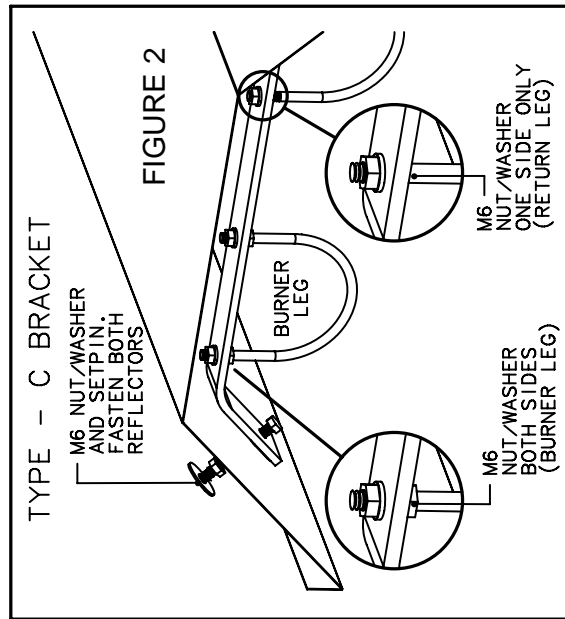

FIGURE 2

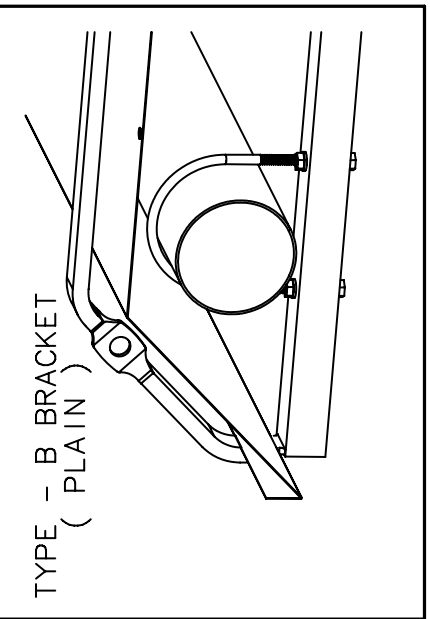
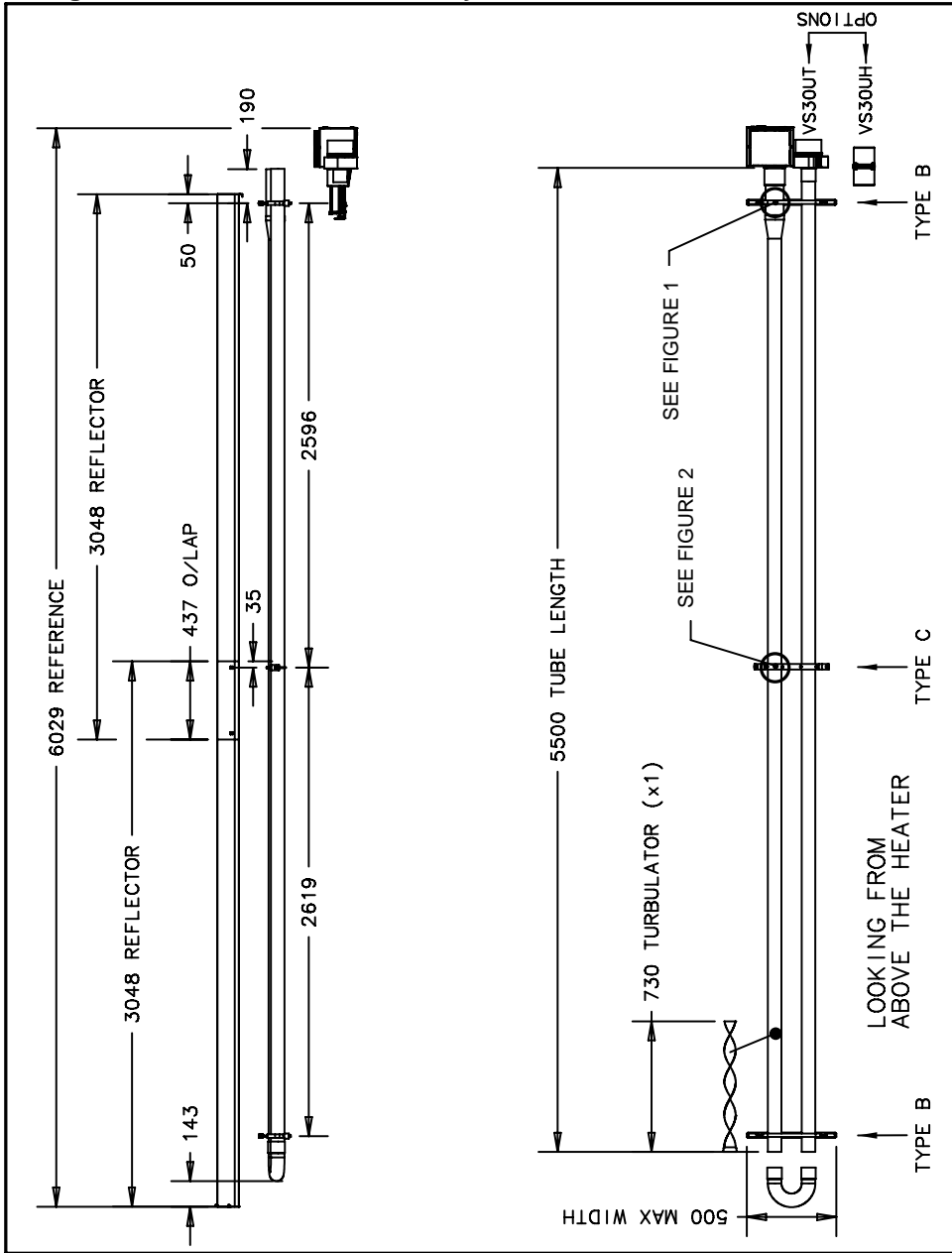

Figure 18. Vision Heater Assembly: Models VS/VSA U tube 30kW.



VISION U-TUBE HEATERS	
VS30UT	
VS30UH	
NOTE :- VSA MODELS HAVE ALUMINISED REFLECTORS AND NO END CAPS. ALL OTHER MODEL DETAILS AS SHOWN.	

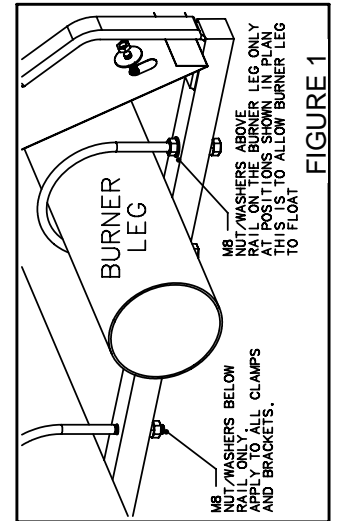

FIGURE 1

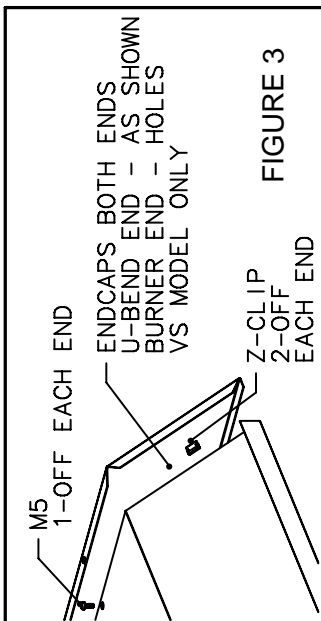

FIGURE 3

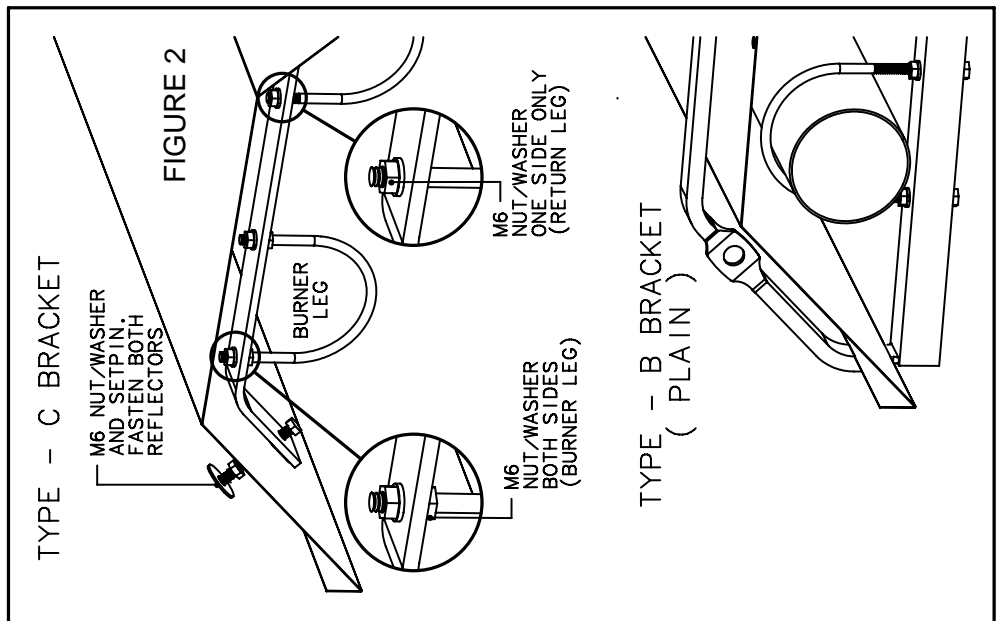

FIGURE 2

Figure 19. Vision Heater Assembly: Models VS/VSA U tube 35/40kW.

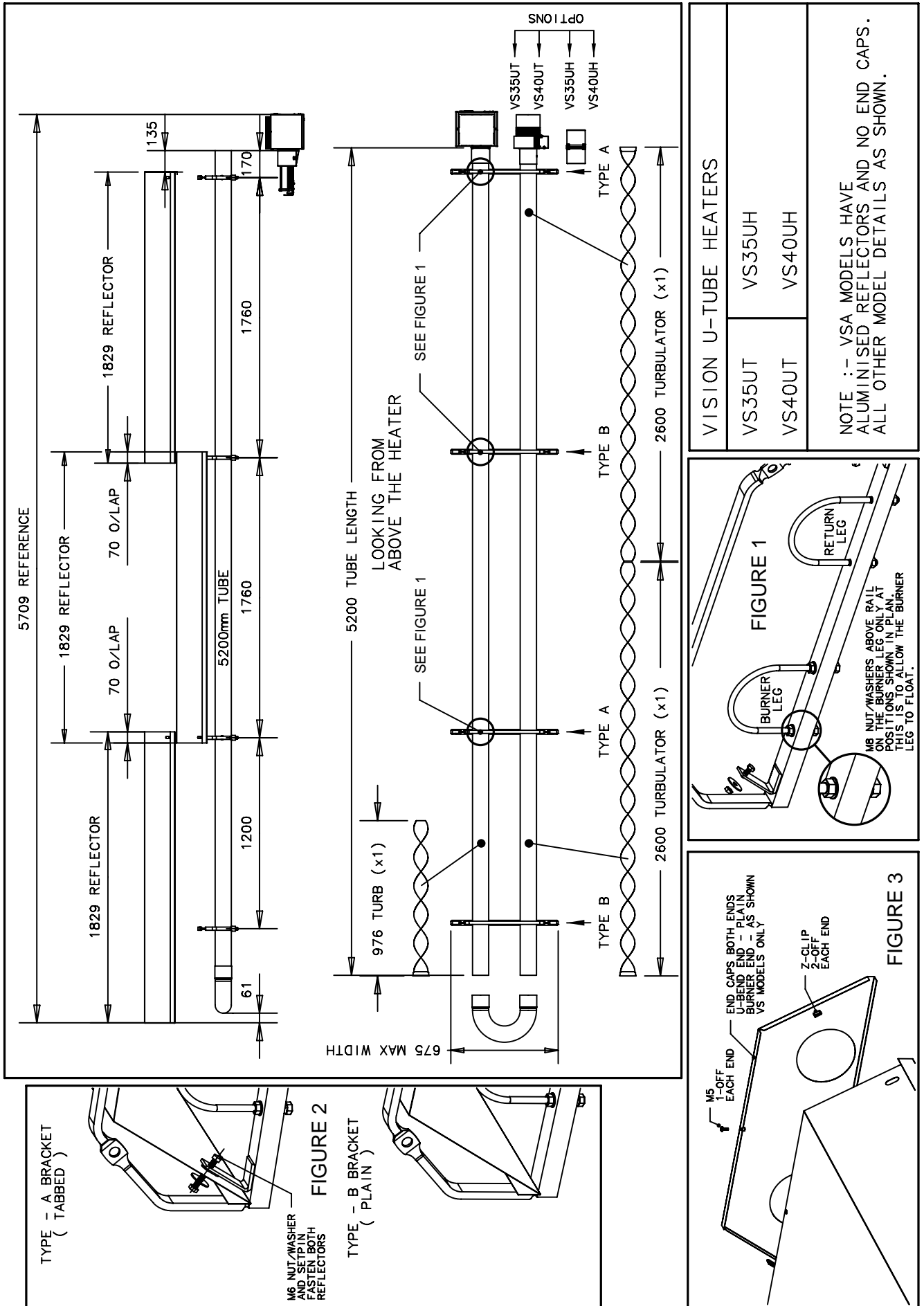

Figure 21. Vision Heater Assembly: Models VSLF/VSDL/VSLHB 15kW 6m - 75mm (3ins) Nom Dia.

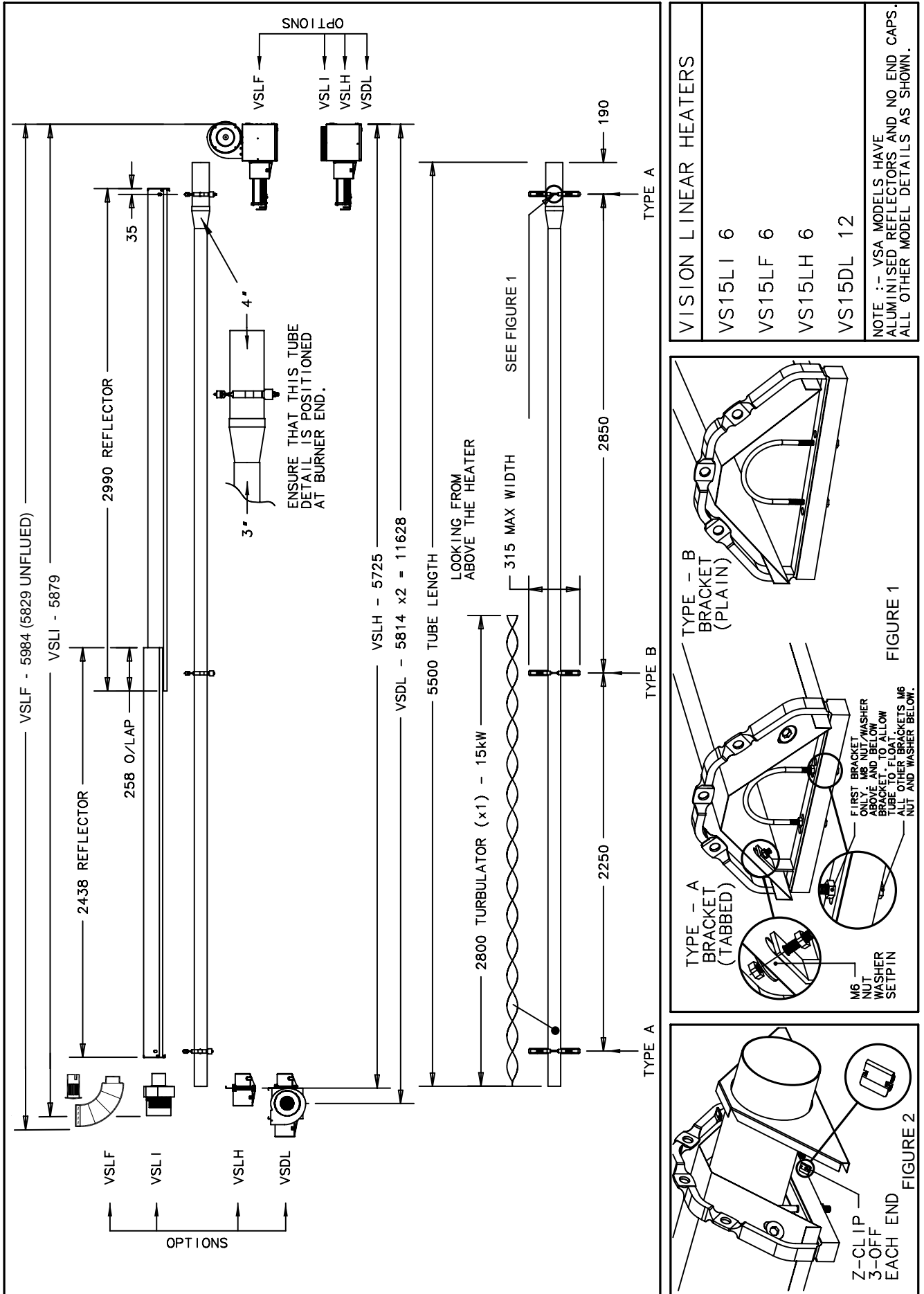
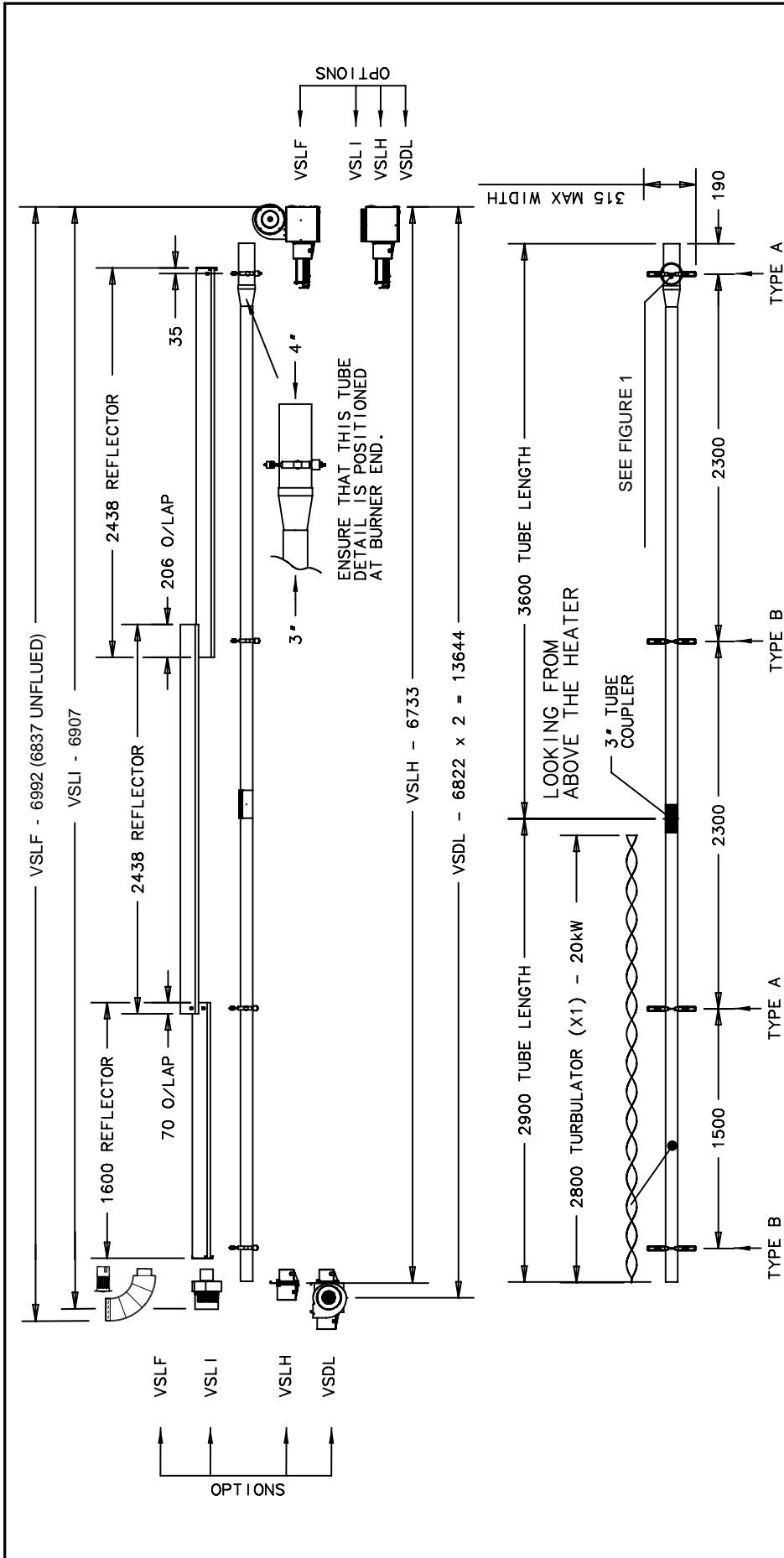
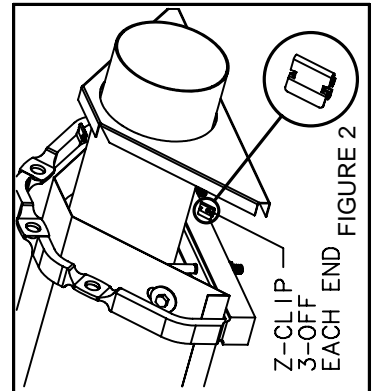
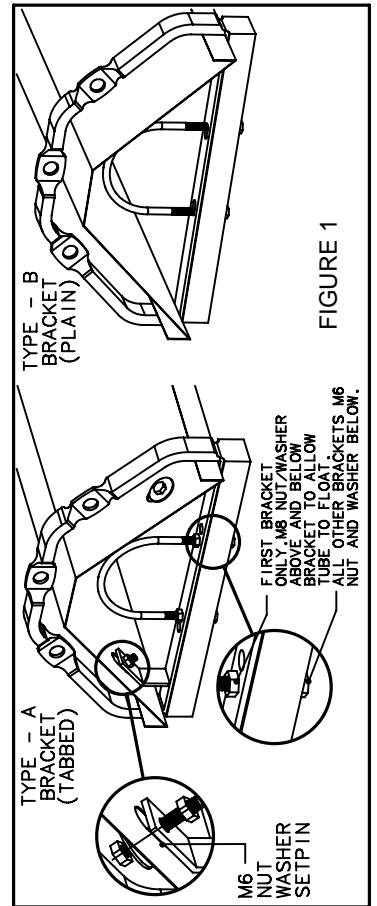

Figure 22. Vision Heater Assembly: Models VSLF/VSDL/VSLHB 20kW 7m - 75mm (3ins) Nom Dia.



VISION LINEAR HEATERS	
VS20LI 7	
VS20LF 7	
VS20LH 7	
VS20DL 14	

NOTE :- VSA MODELS HAVE ALUMINISED REFLECTORS AND NO END CAPS. ALL OTHER MODEL DETAILS AS SHOWN.



23. Vision Heater Assembly: Models VSLF/VSDL/VSLHB 15/25kW 8m - 75mm (3ins) Nom Dia.

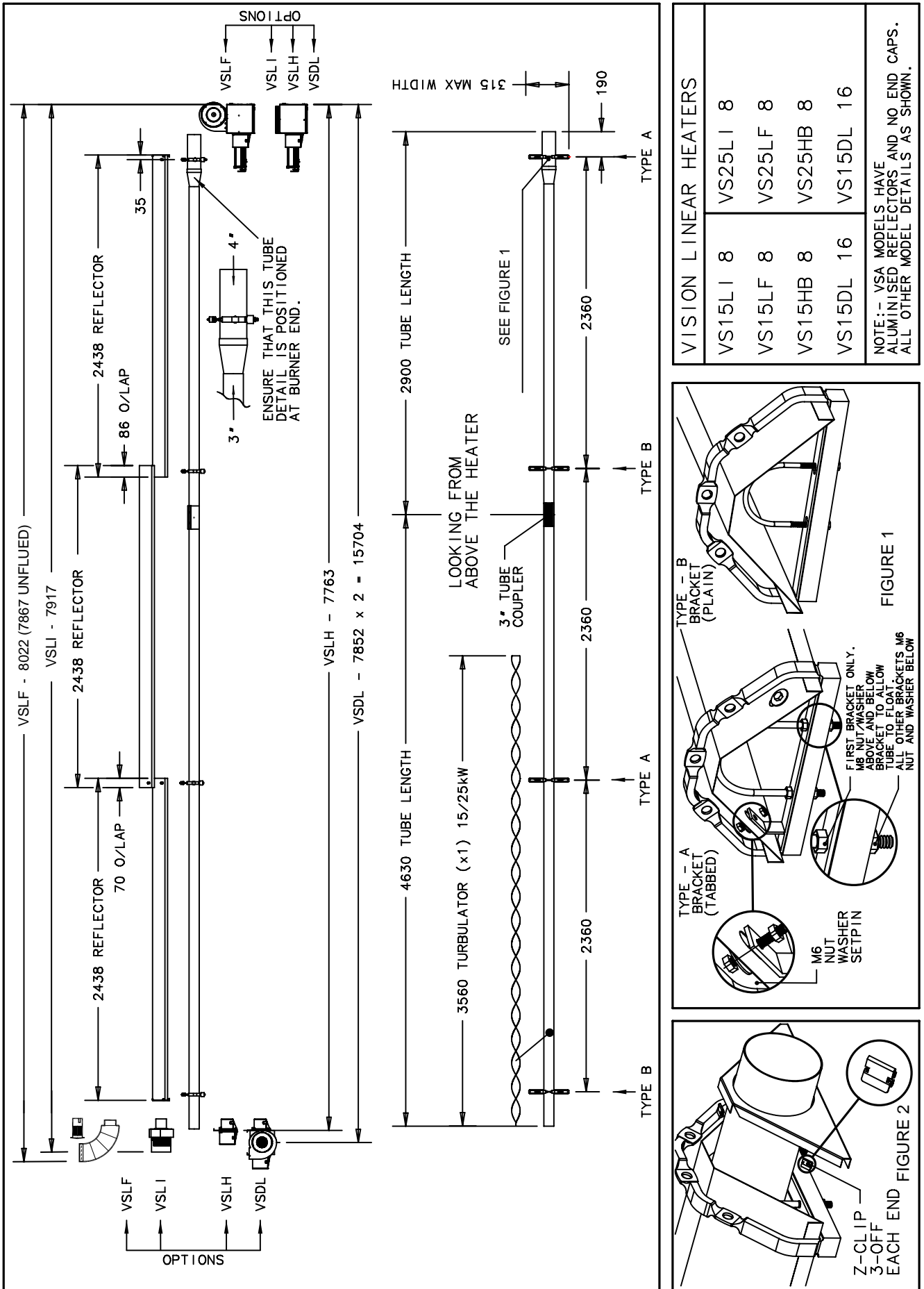

Figure 24. Vision Heater Assembly: Models VSLF/VSDL/VSLHB 20/25/30kW 10.5m - 75mm (3ins) Nom Dia.

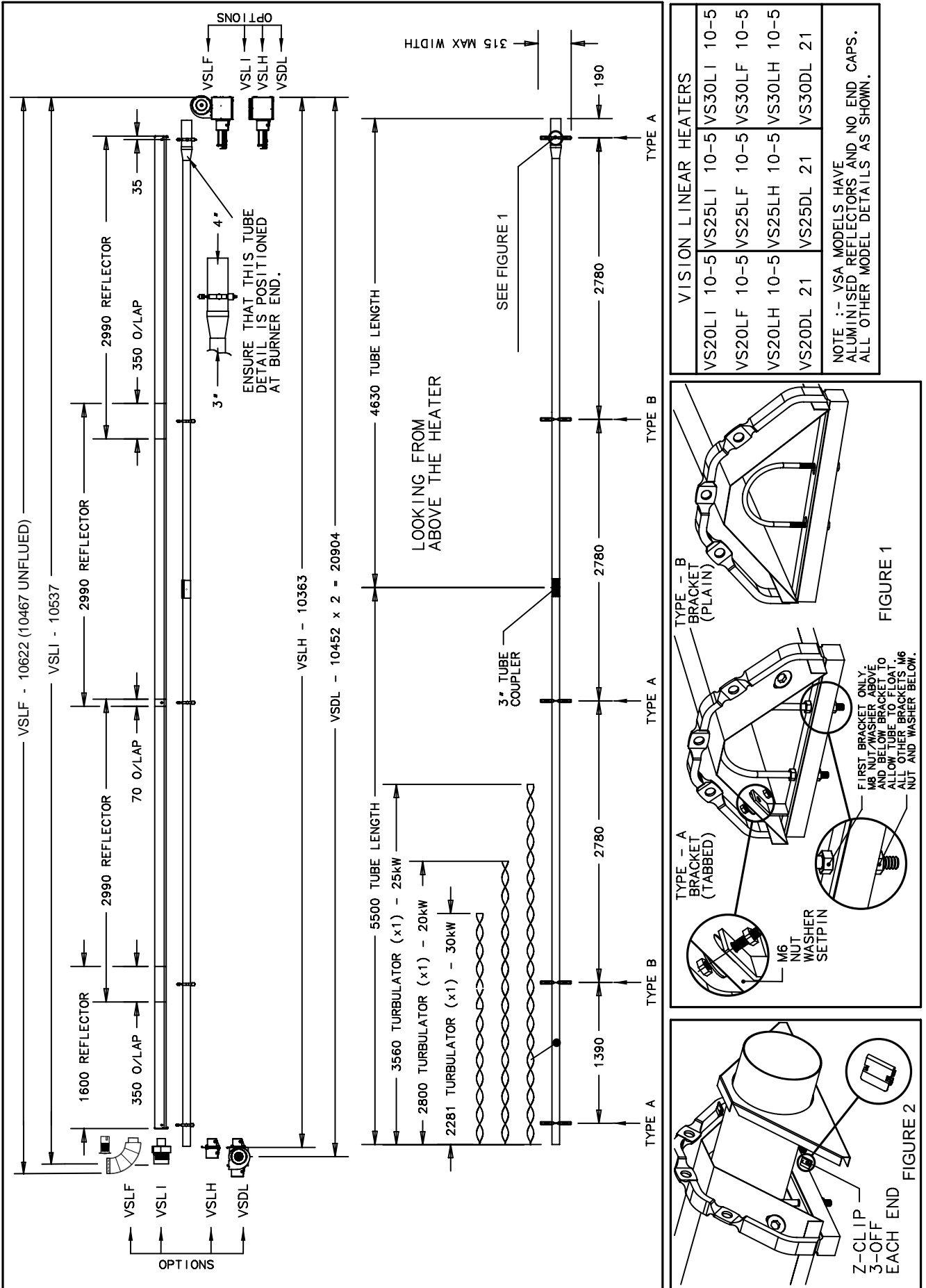

Figure 26. Vision Heater Assembly: Models VSLF/VSDL/VSLHB 35kW - 10.5m - 100mm (4ins) Nom Dia.

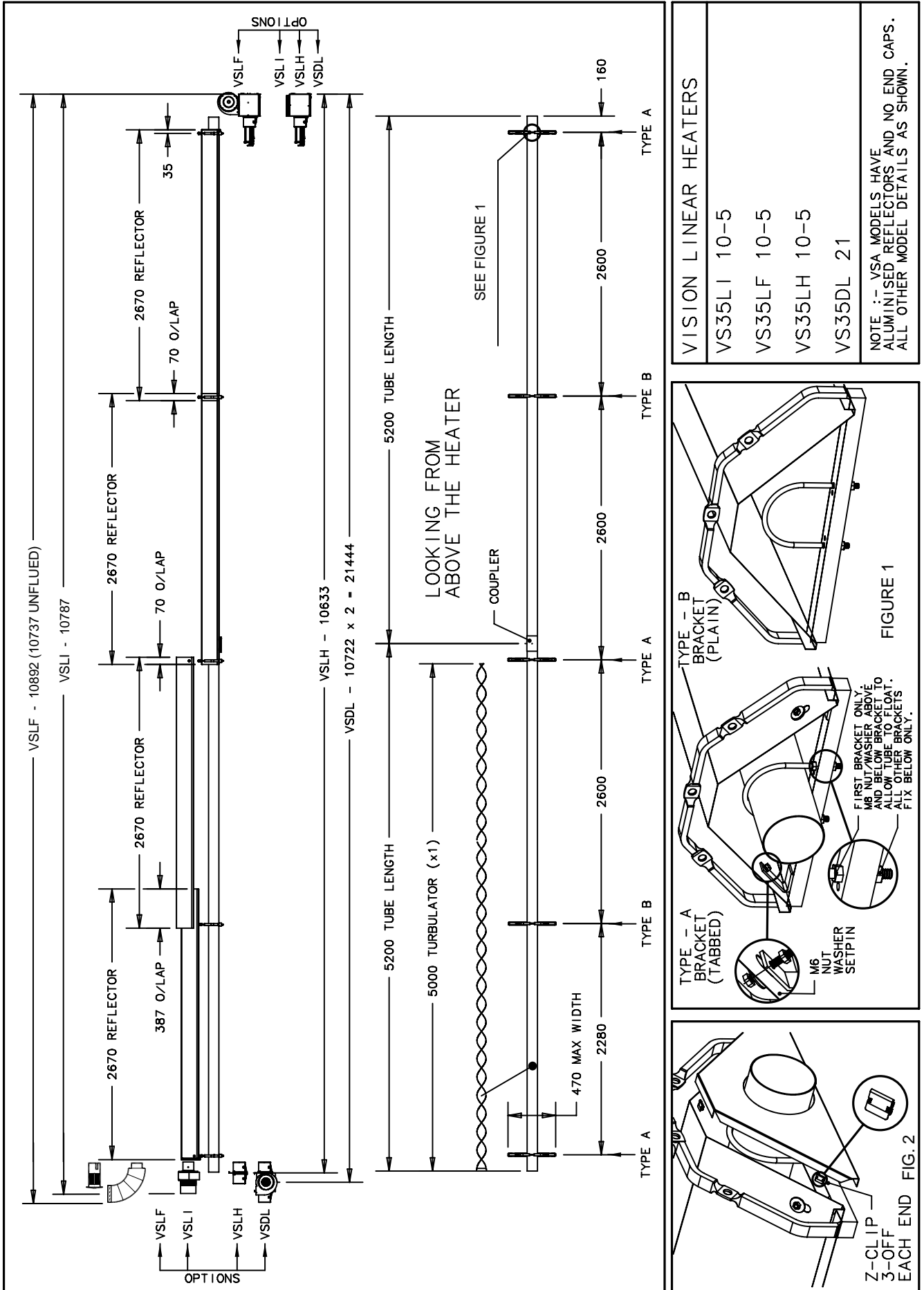
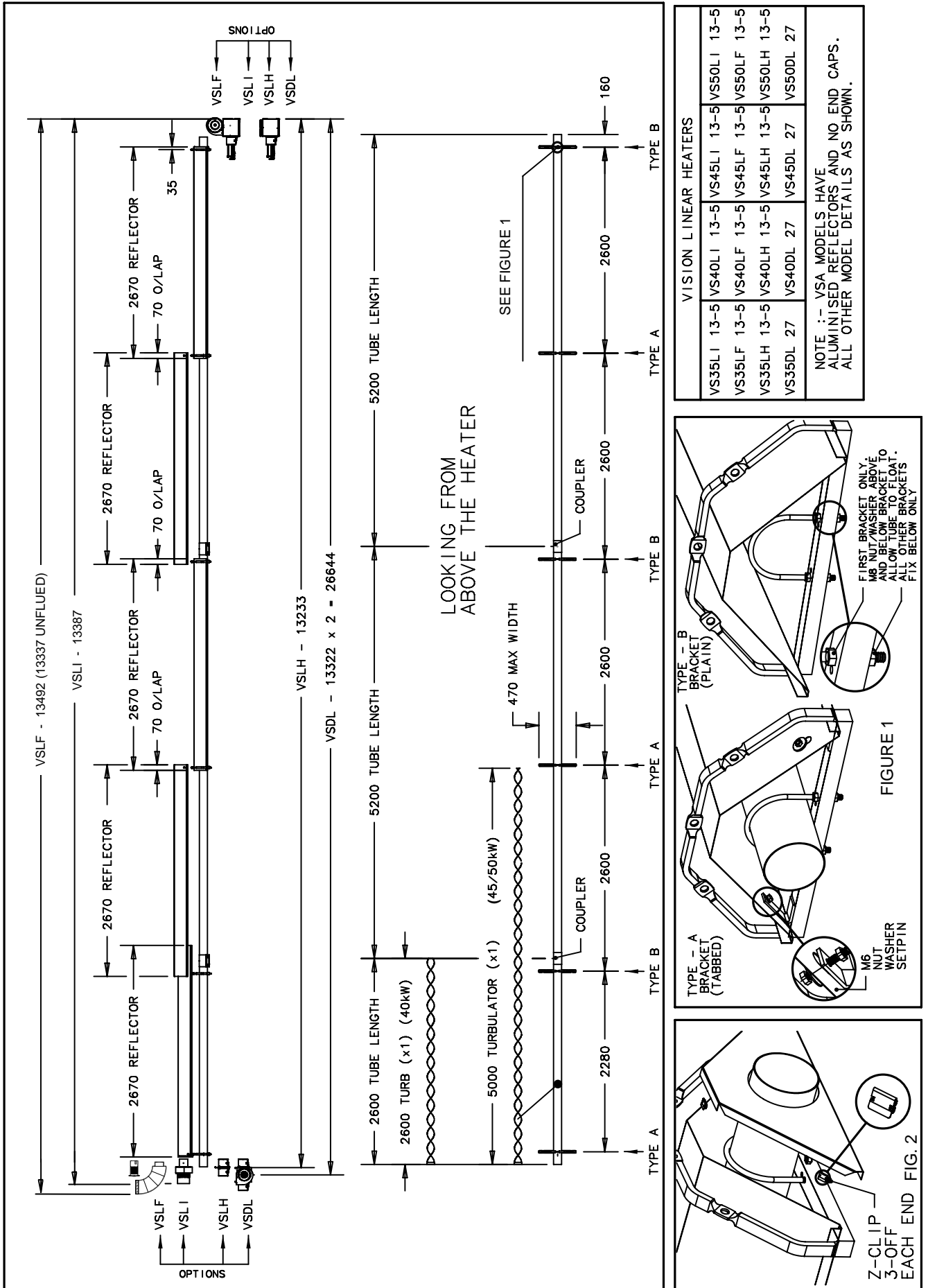

Figure 27. Vision Heater Assembly: Models VSLF/VSDL/VSLHB 35/40/45/50kW - 13.5m - 100mm (4ins) Nom Dia.



3. Commissioning Instructions.

! These appliances should be commissioned by a qualified engineer.

3.1 Tools Required.

The following tools and equipment are advisable to complete the tasks laid out in this manual.

 Suitable alternative tools may be used.



3.2 Balancing The Herringbone System

! Important When all the heaters have been installed the vacuum settings must be finally balanced in the hot condition.

Before attempting to start up the heating system it is essential to perform the preliminary balancing of the vacuum level at each burner unit. Isolate each heater unit by unplugging the electrical connector and closing the gas isolating valve.

Start all burners up and allow them to run for at least 20 minutes. Adjust the damper at exit of each heater using a 4mm Allen key in the damper blade securing screw. Observing the vacuum reading using a 'U' tube manometer connected to the vacuum test point (see figure 29) each damper should be readjusted and set at a hot condition reading as shown in table 6 (page 18) for the appropriate size of heater and model.

Figure 29. HB Damper Assembly

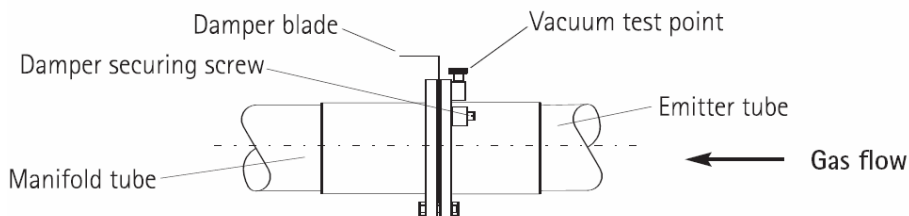

3.3 Balancing a DL System

! Important When all the heaters have been installed the vacuum settings must be finally balanced in the hot condition.

As with a Herringbone system above, start both burners up and allow them to run for at least 20

minutes. Adjust the damper on the condensate box using a 4mm Allen key in the damper blade securing screw. Observing the vacuum reading using a manometer connected to the vacuum test point (see figure 30) each damper should be readjusted and set at a hot condition reading as shown in table 6 (page 18) for the appropriate size of heater and model.

Figure 30. DL Condensate Box Assembly

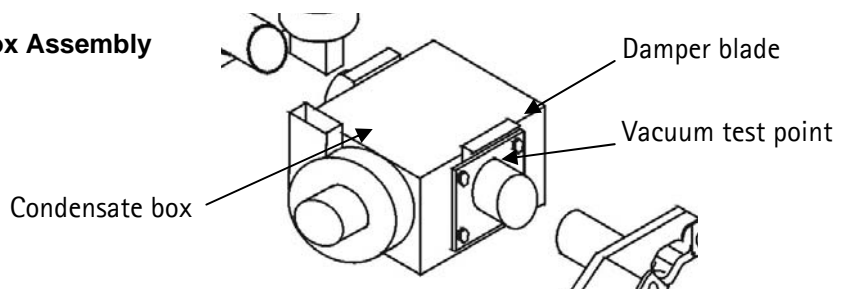

3.4 Commissioning chart for VS series unitary heaters

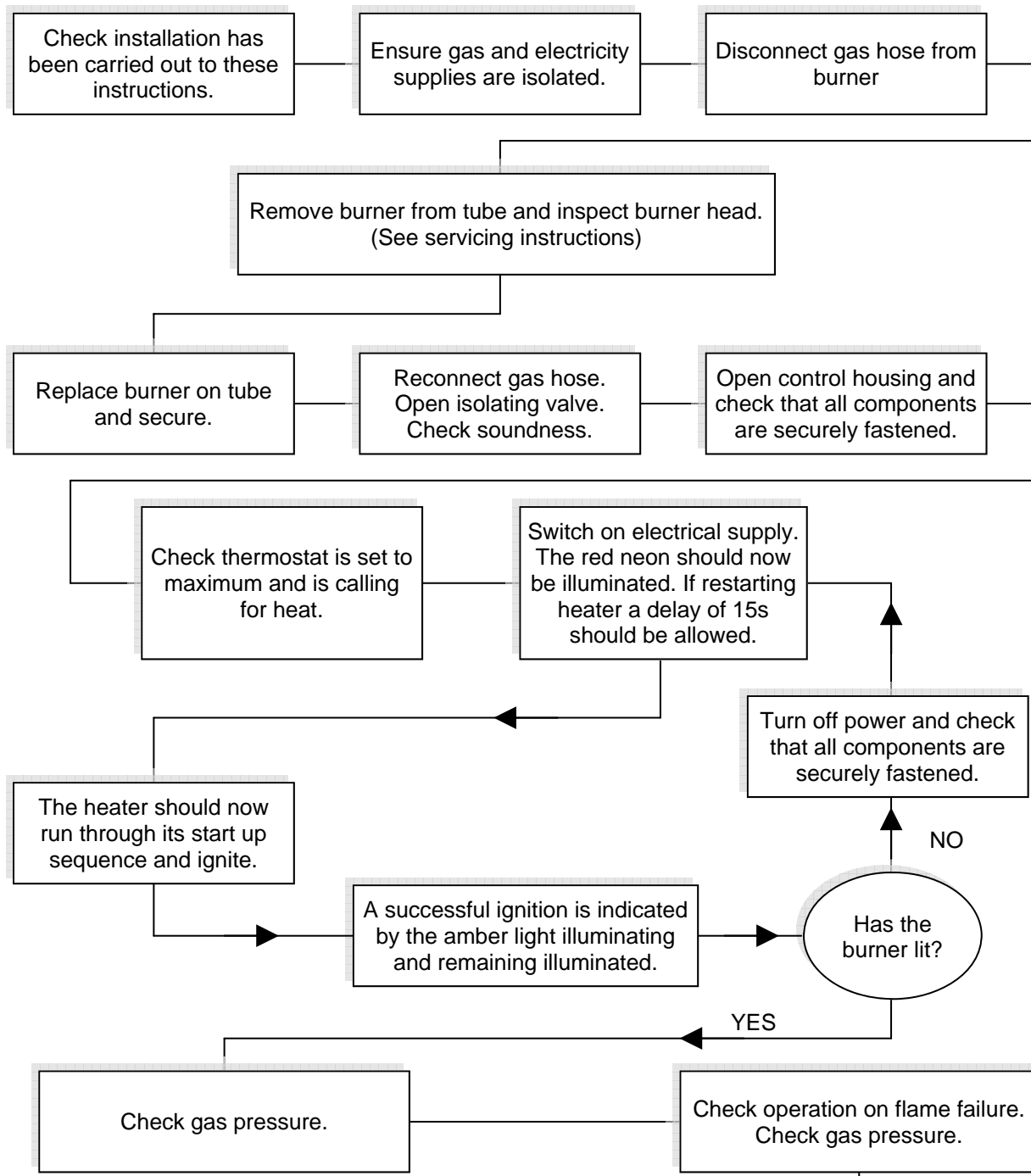

Gas Valve adjustment

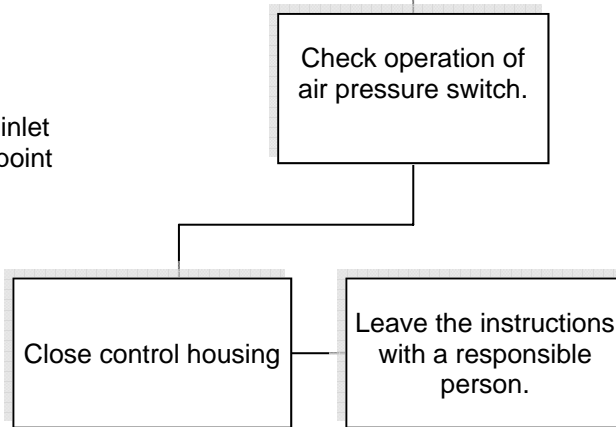
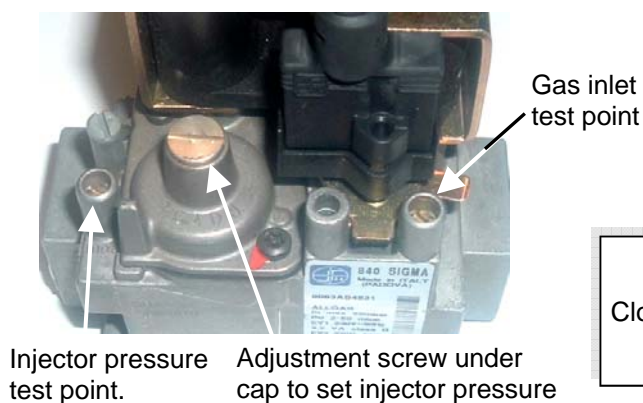

4. Servicing Instructions.



These appliances should be serviced annually by a competent person to ensure safe and efficient operation. In exceptional dusty or polluted conditions more frequent servicing may be required. The manufacturer offers a maintenance service. Details available on request

4.1 Tools Required.



Suitable alternative tools may be used.

The following tools and equipment are advisable to complete the tasks laid out in this manual.



4.2 Burner Description.

Figure 31. Induced Burner: Models VS(A)LI, VS(A)LH, VS(A)UH and VS(A)DL

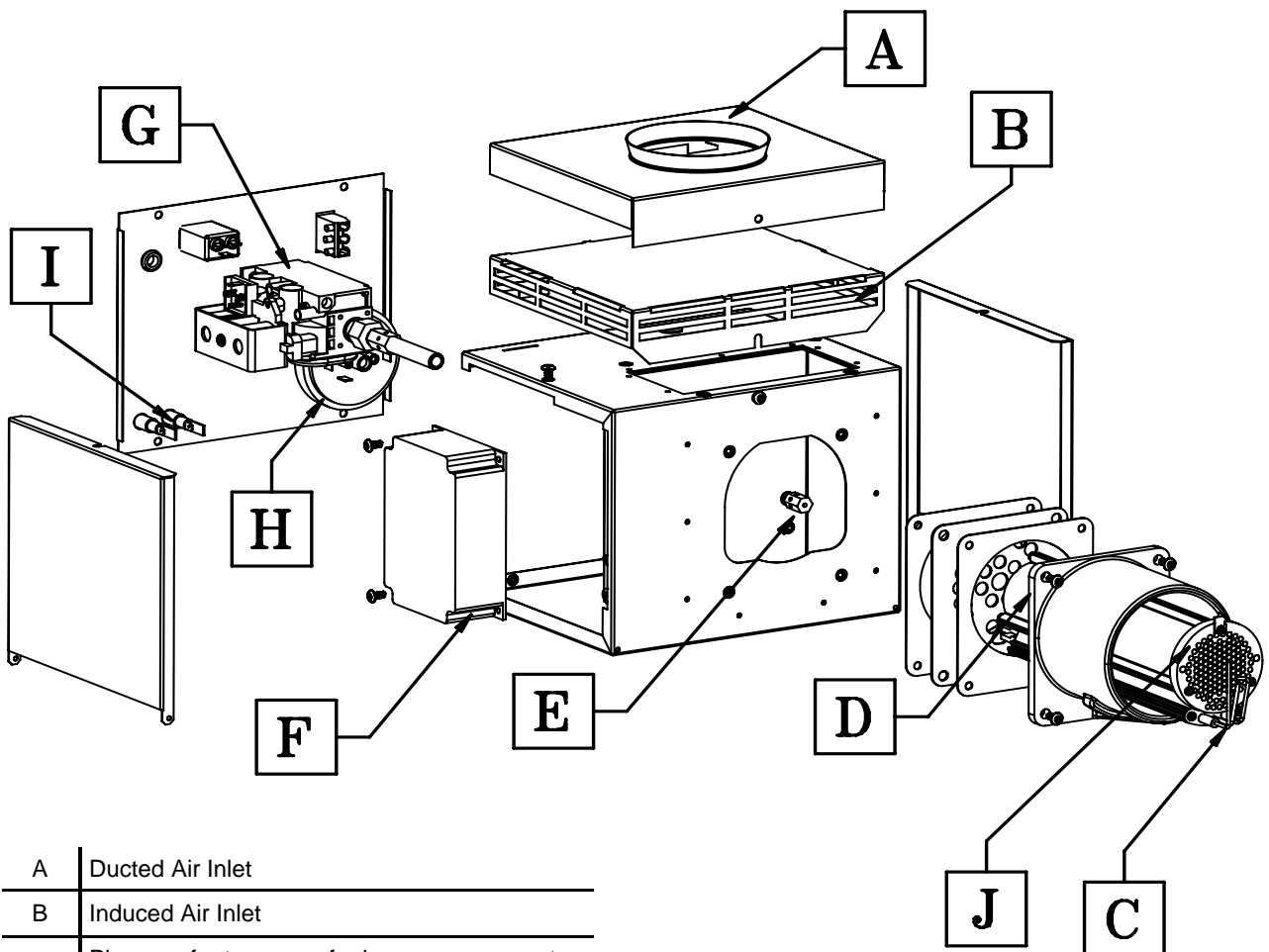

A	Ducted Air Inlet
B	Induced Air Inlet
	Please refer to spares for burner components
C	Ignitor Assembly
D	Extruded Burner Head
E	Multi Hole Injector
F	Ignition Controller

G	Gas Valve
H	Pressure Switch
I	Neon's (Red/Amber)
J	Pepperpot Head

Figure 32. Forced Gas Burner: Model VSLF

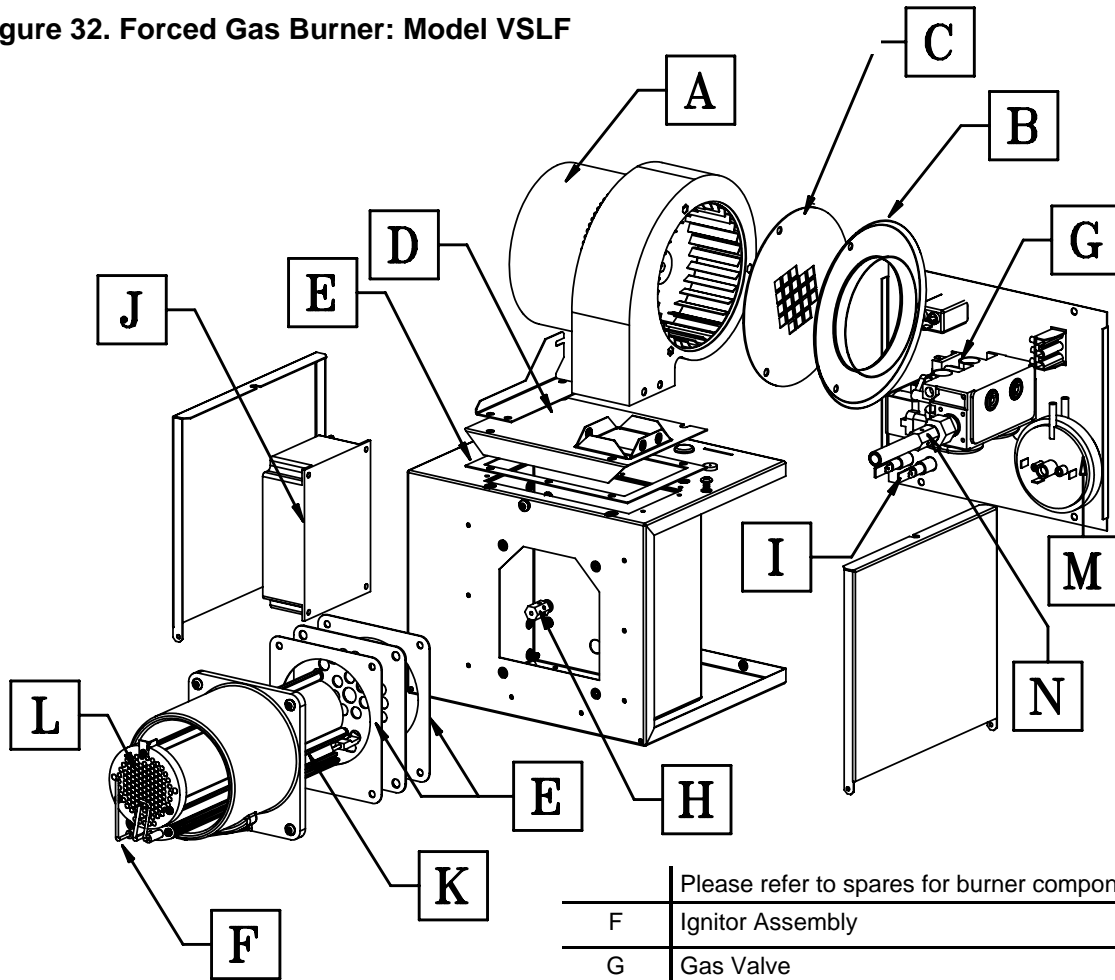

A	2501 or 2507 Fan
B	Fan Inlet Spigot
C	Fan Orifice plate
D	Fan Mount Plate and Support
E	Gasket Set

	Please refer to spares for burner components
F	Ignitor Assembly
G	Gas Valve
H	Multi Hole Injector
I	Neon's (Red/Amber)
J	Ignition Controller
K	Extruded Burner Head
L	Pepperpot Head
M	Pressure Switch
N	Jet Carrier

4.3 Burner Removal (All Options)

! Step 1 Isolate mains electric and gas supplies. Unplug the fan and mains electricity connectors.

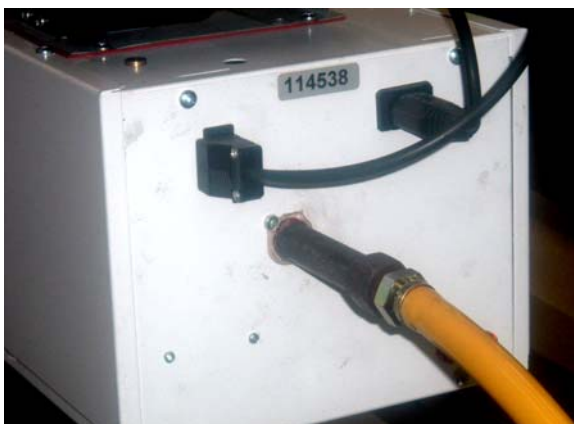

Step 2 Detach the gas supply as shown below, taking care to support the burner connection.

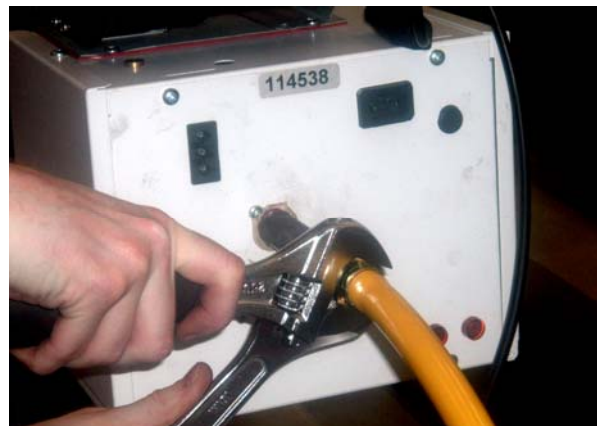

Step 3 On forced burners with ducted air attachment slacken jubilee clip and remove the flexible hose from the fan.

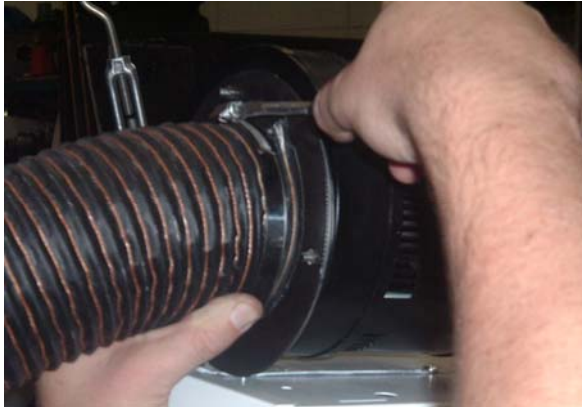

Step 4 Slacken the grub screw on the burner support casting using a 4mm Allen key to enable the burner to be removed from the radiant tube.



Step 5 Carefully remove the burner to prevent it or any components from falling to the ground and position the assembly in a safe area.

4.4 Burner Gas Injector Servicing

Step 1 Remove the burner support casting and gasket.



Step 2 The burner head assembly can be disconnected by separating the connectors of

the ignition lead assembly and removing the pressure switch silicon tube.

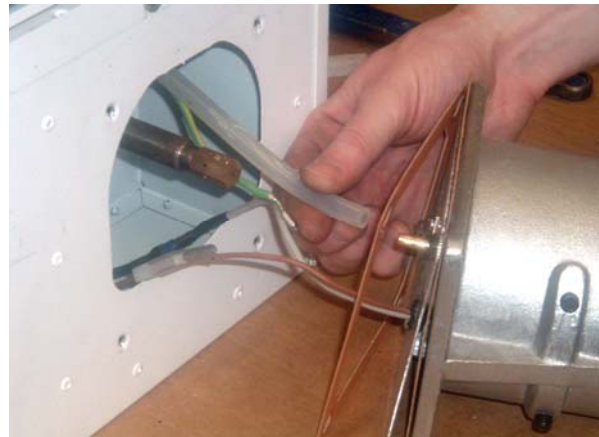

Step 3 The gas injector can be inspected and replaced if contaminated or blocked.



 When replacing the gas injector use a 12mm spanner and ensure approved thread sealant is used.

Step 4 Refit the burner support casting and replace the gaskets to ensure effective sealing.

4.5 Burner Head and Electrode Servicing

Step 1 Check the pepper pot burner head for contamination. If necessary the head can be removed for cleaning of the inside of the burner head, see below.



Step 2 The pepper pot burner head can be replaced ensuring the 5 holes on the outer ring are aligned alongside the probes.



Step 3 The condition of the ignitor assembly can be checked for deterioration. However, we advise replacement at each service to ensure continued reliability.

Step 4 Detach the electrode assembly from the burner head by removing the two screws and separating the ignitor lead connectors.

Step 5 Refit the electrode assembly and ensure the silicon sleeving is fitted as shown above to prevent arcing of the spark electrode.

Step 6 Check the positions and spark gap as shown below.

Step 7 The burner assembly is ready to refit after servicing the combustion fan and the radiant tube assembly.

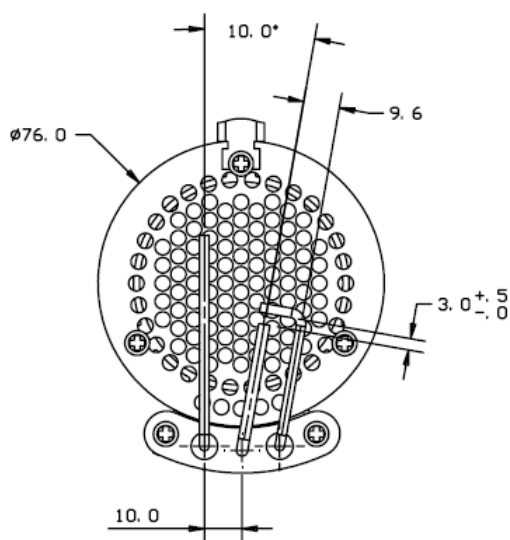

4.6 Combustion Fan Assembly Induced Burner (Model VSLI/VSALI)

Step 1 Loosen the clamp fitting on the flue

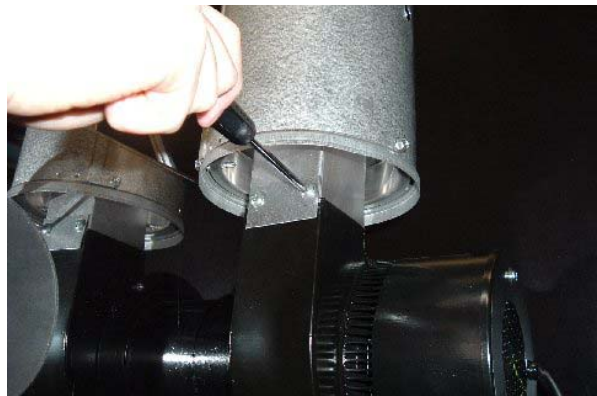

Step 2 Loosen the 4mm grub screw.

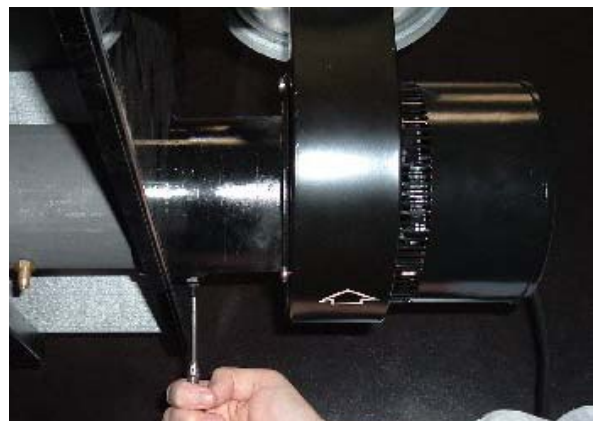

Step 3 The combustion fan can now be detached.

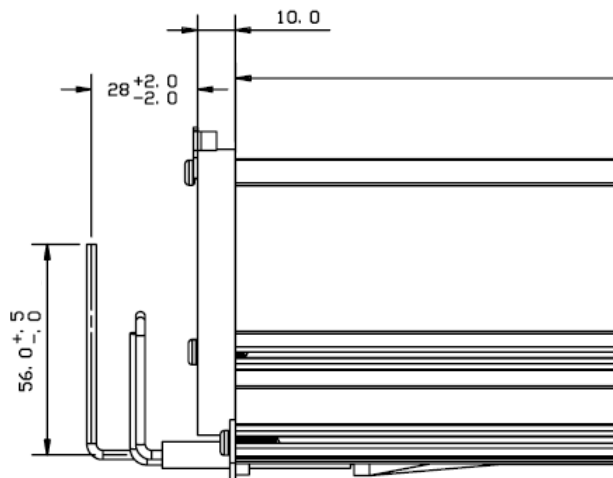

Figure 33. Burner head detail

Step 4 Remove the fan orifice plate spinning.



Step 5 Inspect the impeller and remove any dust with a soft brush.



Step 6 Remove any dust from fan scroll and from around the motor.

Step 7 Ensure the impeller rotates freely.

Step 8 Refit components.

4.7 Combustion Fan Assembly Forced Burner (Model VSLF only)

Step 1 On Forced burners with ducted air attachment slacken jubilee clip and remove the flexible hose from the fan.



Step 2 Remove fan spigot fixings.

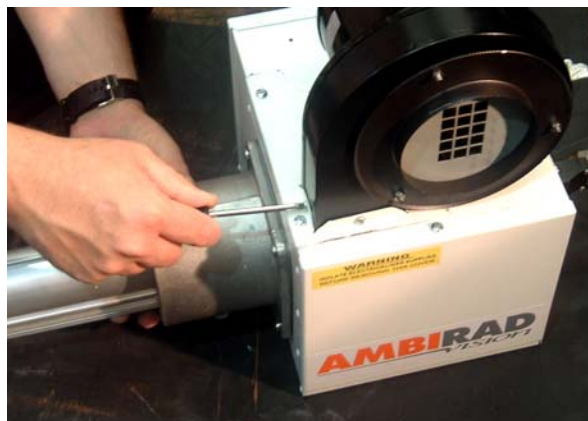

Step 3 The combustion fan can now be detached.

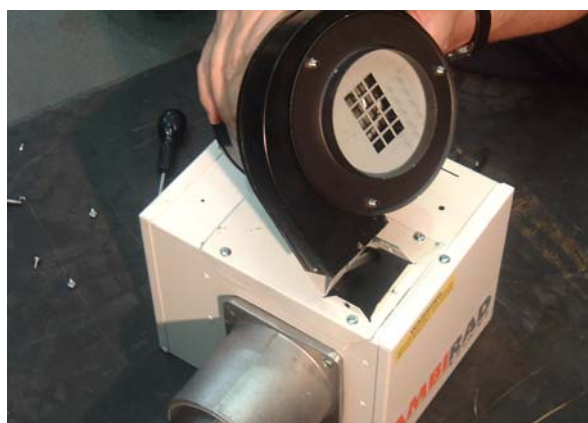

Step 4 Remove the fan orifice plate spinning.

Step 5 Inspect the impeller and remove any dust with a soft brush.

Step 6 Remove any dust from fan scroll and from around the motor.



Step 7 Ensure the impeller rotates freely.

Step 8 Refit components.

4.8 Radiant Tube Servicing

Step 1 Brush any dust from the exterior of the tubes.

Step 2 Inspect the fan and burner tubes visually. If the tubes appear clean, skip to servicing the reflector.

Step 3 Remove the U bend (or damper - HB products or condensate box - DL products)

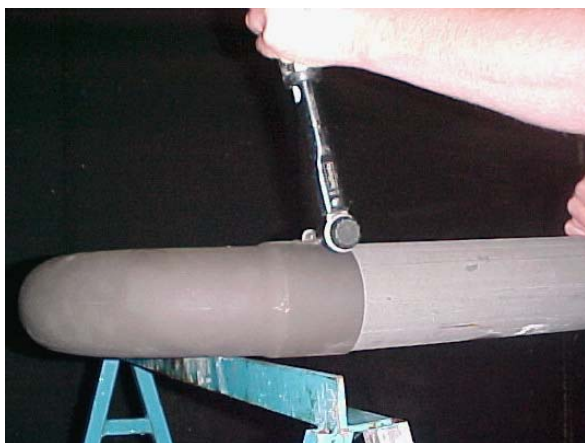

Step 4 Withdraw the turbulators from the appliance. Carefully noting their condition and position. Replace turbulators if necessary.



Step 5 The turbulators should be cleaned with a soft brush.



Step 6 If required the interior of the tubes can then be cleaned using an industrial vacuum cleaner or by using long poles and a scraper.

Step 7 Refit components.

4.9 Reflector Servicing

The condition of the reflectors should be noted. If necessary the reflectors can be cleaned with a mild detergent.

 This can significantly improve the efficiency of the appliance.

4.10 Inspection of Flue

The flue needs to be inspected and cleaned if necessary or in accordance to the regulations of the country that the appliance is installed.

4.11 Re-commissioning After Service

After servicing of the heater has been undertaken, it will be necessary to re-commission the heater as detailed in Section 3 of these instructions.

5. Spare Parts.

Required Spares

In order to aid troubleshooting and servicing we recommend that the components shown in this section should be stocked.

 *Note Any spare part components that are not approved by AmbiRad could invalidate the approval of the appliance and validity of the warranty.*

Item	Description	Part No.	Item	Description	Part No.
	Ignition Controller	2015S		Pressure Switch: VSLF All others	M101355 201013
	Valve Twin sol reg 220/240	201587		Amber Neon (Burner On)	2175
	Pepperpot Head	200988		Red Neon (Mains On)	2180
	Ignitor Assembly	201284		Combustion Fan	See Section 1.11
	Extruded Burner Head	200358		Flame Plate (VS20/25 ONLY)	201358
	Injector	See section 1.11		Gasket Set	201488
	Jet Carrier (all except *)	200420		Burner Head Wiring Harness	900225
	Jet Carrier * VS50 UT/UH/LI/LH/DL	201630			

6. Fault Finding Guide.

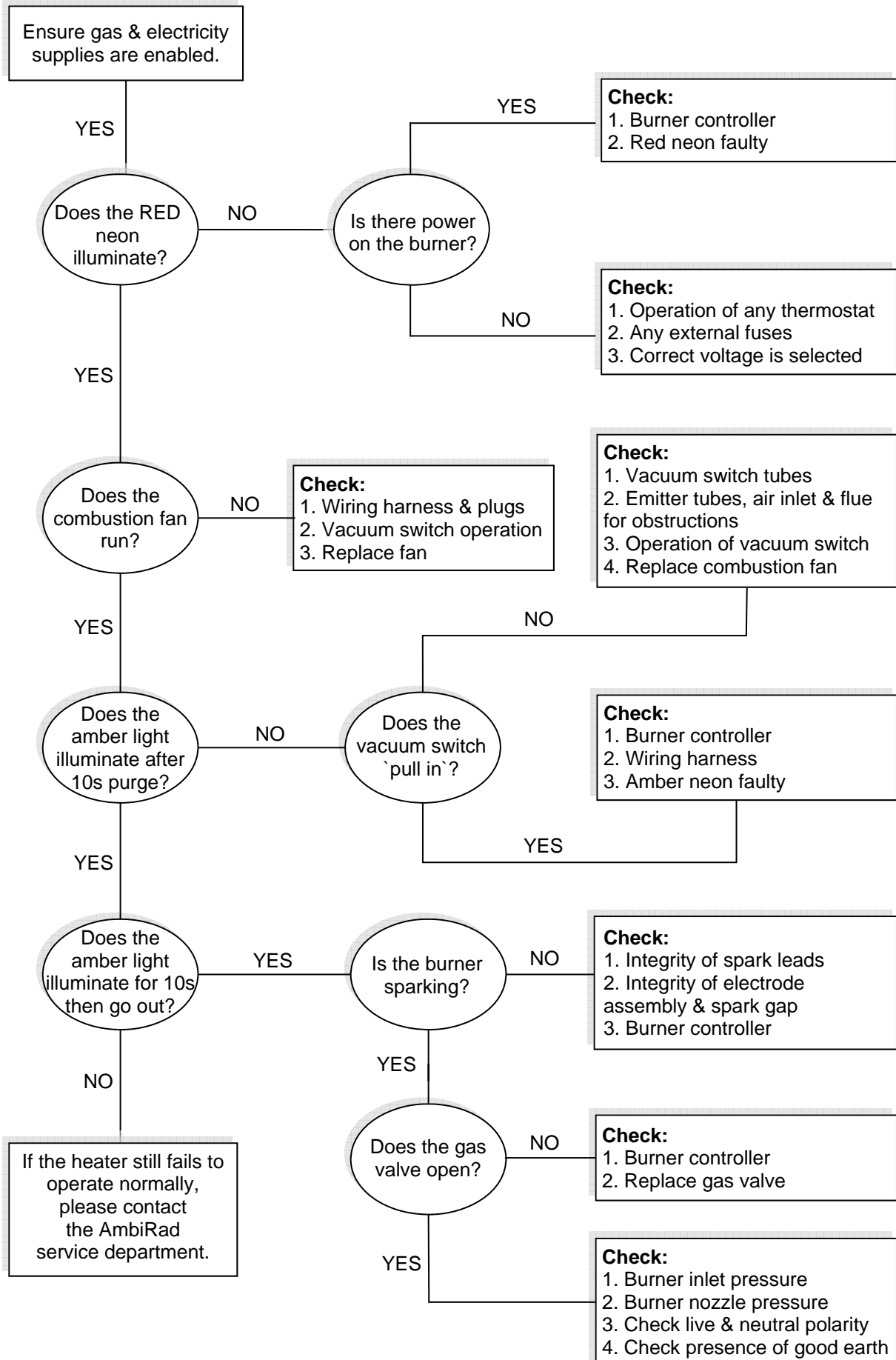

7. Replacing Parts.

7.1 Burner Controller Replacement

Step 1 Slacken screw in burner lid and open the right hand burner access door.

Step 2 Disconnect burner controller from the wiring harness.

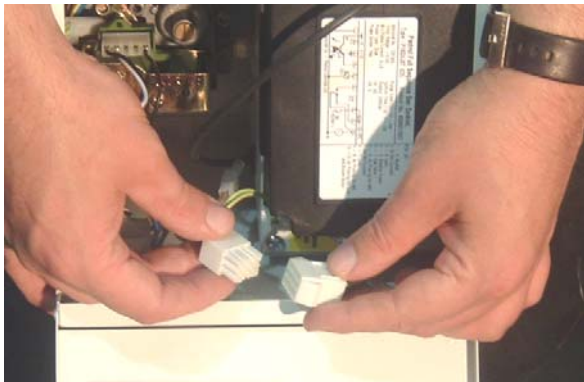

Step 3 Disconnect the HT Lead from burner controller



Step 4 Remove the two screws attaching the controller to the burner and remove.

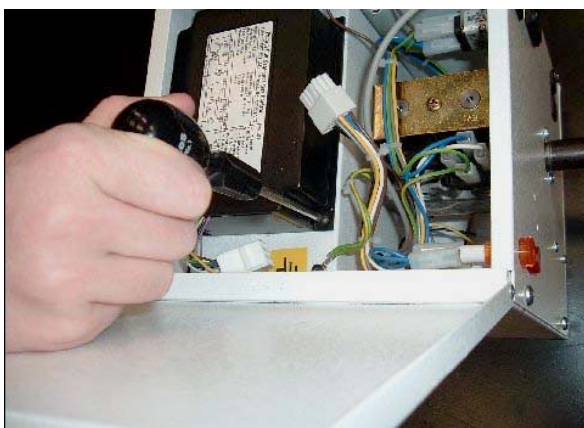

Step 5 Fit new burner controller

Step 6 Refit HT leads and refit burner controller to wiring harness.

Step 7 Test product and close access door.

7.2 Air Pressure Switch Replacement

Step 1 Disconnect the two silicone impulse tubes.

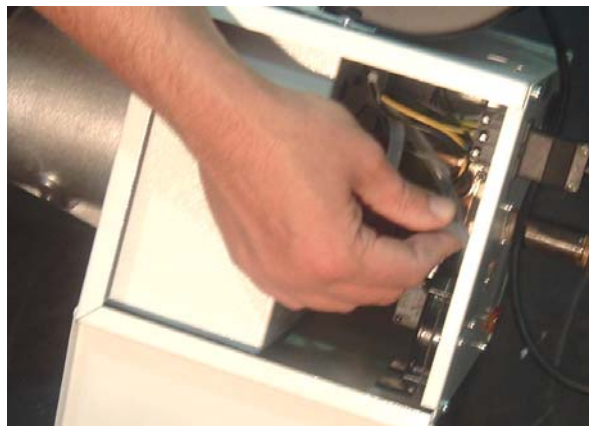

Step 2 Remove the two screws as shown below.



Step 3 The air pressure switch can now be removed.

Step 4 Fit the new air pressure switch ensuring the impulse tubes are connected as shown below.



Step 5 Test product and close access doors.

7.3 Gas Valve Replacement

Step 1 Remove the burner assembly as described in the Servicing Sections.

Step 2 Open the right hand access door and detach the burner controller from the wiring harness.

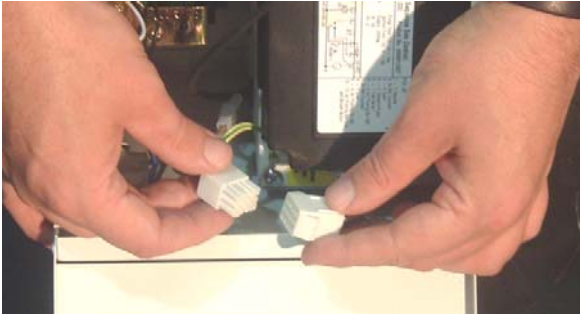

Step 3 Open the left hand access door and detach the impulse hoses from the air pressure switch.



Step 4 Remove the 4 screws holding the burner head onto the burner assembly.

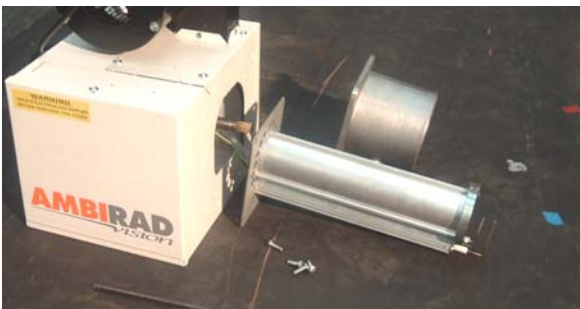

Step 5 The burner head can now be detached by disconnecting the impulse tube and the burner head wiring.

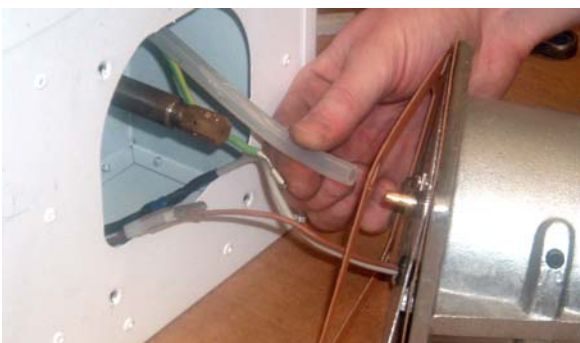

Step 6 Detach the two screws holding the front of the gas valve.

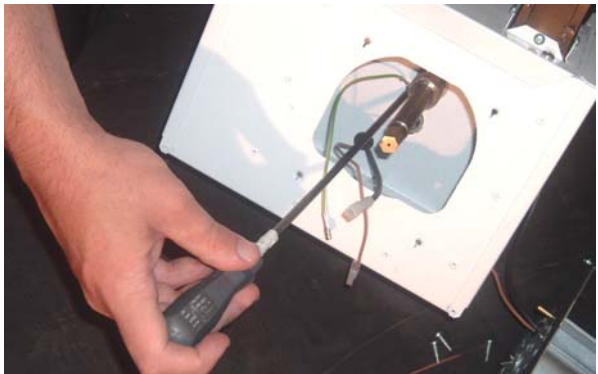

Step 7 Remove the four screws holding the rear burner plate in position.

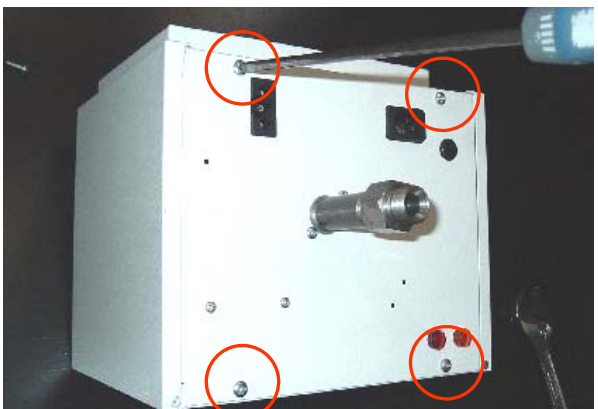

Step 8 Remove the rear plate.

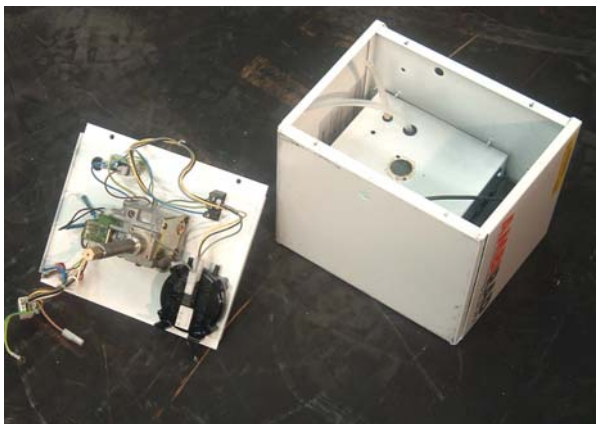

Step 9 The jet carrier, gas inlet, and wiring harness can now be detached from the gas valve.

Step 10 The two screws retaining the gas valve can then be removed.

Step 11 The gas valve can now be replaced.

Step 12 Refit all components.

Step 13 Set pressures and ensure reliable burner performance.

Step 14 Test product and close access door.

Notes.



Notes.



8. User & Operating Instructions.

8.1 To Start the Heater

1. Ensure gas supply is turned on.
2. Electrical supply to the controls is on.
3. Ensure that the controls are correctly set i.e.;

 - Clock is correctly set.
 - Heater program is correctly set.
 - Required room temp is correctly set

4. Once the heating controller 'calls for heat' power will be supplied to the heater(s). The red neon will then illuminate.
5. After a pre-purge period of 10 seconds the burner will ignite and the amber neon will then illuminate.
6. If lockout occurs press the lockout reset button (if available), or switch off electrical supply and restart after 15 seconds.
7. If lockout occurs three times consecutively switch off and isolate the gas and electricity supplies.

Call an AmbiRad Service Engineer.

8.2. To Switch Off Heater

1. Switch off electrical supply to the heater. The burner will stop and the fan will shut off.
2. If the heater is to be switched off for periods in excess of one week it is highly recommended that both the gas and the electrical supplies are turned off.

8.3. Routine Maintenance between Service Intervals

After ensuring that the heater is cold and mains electric isolated, cleaning of the reflectors with a soft cloth and a mild detergent (non solvent based cleaners only) in water can be undertaken.

Additional removal of dust from the radiant tubes, burner and heat exchanger can be undertaken.

8.4 Frequency of Servicing

The manufacturer recommends that to ensure continued efficient and safe operation of the appliance it is recommended that the heater is serviced annually by a competent person e.g. every year in normal working conditions but in exceptional dusty or polluted conditions more frequent servicing may be required.

The manufacturer offers a maintenance service.

Details are available on request.

For Service requirements, please contact AmbiRad

For further technical and service support visit our Support Information Database at www.s-i-d.co.uk



AmbiRad Limited Fens Pool Avenue
Brierley Hill West Midlands DY5 1QA
United Kingdom.

Telephone 01384 489700
Facsimile 01384 489707
Email info@ambirad.co.uk
Website www.ambirad.co.uk
Technical Support www.s-i-d.co.uk

AMBIRAD
ENERGY EFFICIENT HEATING SYSTEMS

AmbiRad is a registered trademark of AmbiRad Limited. Because of continuous product innovation, AmbiRad reserve the right to change product specification without due notice