



# LCSA Series

ROOM SEALED GAS FIRED UNIT HEATERS



# LCSA Series

## ROOM SEALED GAS FIRED UNIT HEATERS



### Introduction

LCSA compact gas fired suspended warm air heaters utilise a tubular heat exchanger to provide a simple low cost heating solution suitable for all standard industrial and commercial heating applications.

LCSA fan-assisted balanced flue units incorporate an integral flue gas exhaust fan to induce combustion air mechanically from outside the building. This same fan then exhausts the products of combustion back to the outdoor atmosphere. A single balanced flue terminal provides a combined air inlet and flue outlet.

Units are CE certified as either balanced flue appliances or fan assisted flue units, where combustion air is drawn from the heated space.

Each unit is fitted as standard with a high capacity axial fan and fully adjustable curved blade horizontal discharge louvres.



### Model Range

The LCSA Series gas fired heaters are available in four sizes, with heat outputs ranging from 35kW to 73kW, for use on natural gas or LPG (optional).

### Features & Benefits

- High thermal efficiency - 91% plus resulting in lower running costs (based on net calorific value)
- Multi-try ignition system for enhanced reliability
- Dual limit stats for additional safety.



### Specification

#### Heat Exchanger

Tubular aluminised steel heat exchanger complete with multiple in-shot burners.

#### Air Distribution

A high capacity axial flow fan is fitted to all units for improved air distribution. An optional Economy Thermostat may be fitted to heaters installed at high level to recycle warm air down to working level when the burners are switched off.

The fan operation is controlled by an integral controller which delays fan start-up until the heat exchanger has reached operating temperature and continues to run after the burner has switched off until all the useful heat has been dissipated.

#### Enhanced Safety & Reliability

To ensure safe automatic operation, each unit is fitted as standard with comprehensive safety controls. Ignition is controlled and monitored from a multi-try electronic sequence controller and gas safety shut-off valve. A differential pressure switch shuts off the burners if either the flue or combustion air supply is obstructed or the flue exhaust fan fails. A limit thermostat protects the unit from overheating and a second higher limit thermostat is fitted to provide dual safety control.



## Installation

Units may be suspended or alternatively mounted on a suitable non-combustible support. Four integral suspension points complete with an M10 female thread are provided to each heater.

The balanced flue terminal provides both the combustion air inlet and flue outlet from a single building penetration. The terminals are ordered separately from the heaters to suit either a wall or roof outlet. Additional flue and combustion air pipes may be added, up to a maximum of nine metres of flue pipe, plus nine metres of combustion air pipe. (This reduces by 1.5 metres for every 90° bend fitted.)

To comply with CE approvals, balanced flue appliances must be used with the manufacturer's balanced flue system.

The units are also certified for fan assisted flue installations, where the combustion air is to be drawn from within the heated space; an alternative wall or roof terminal is required for this application.

A single phase electrical supply is required to each unit. This supply should not be switched off except for maintenance.

Units must not be installed in atmospheres containing highly flammable or explosive vapours, combustible dust, halogenated hydrocarbons or chlorinated vapours. They are also unsuitable for areas where contaminants may affect electrical motors or connections.

## Ease of Maintenance

All controls are housed behind a hinged service door situated on the right hand side when viewed from the front.

## Certification

Units are designed and tested in accordance with current European CE Standards.

## Applications

- Factories
- Greenhouses
- Warehouses
- Workshops

## ECA



Authorised User No. 00011

This symbol verifies that the product was independently assessed and qualifies for the ECA scheme, an upfront tax relief enabling businesses that invest in energy-saving equipment to claim 100% first-year capital allowances against their taxable profits.

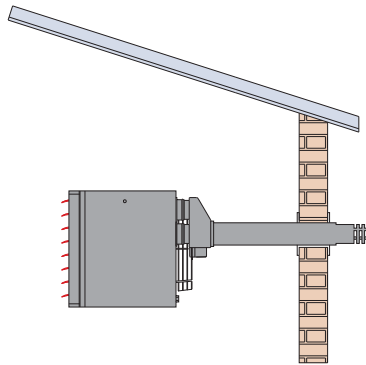

Balanced flue wall outlet (type C12) eliminates expensive roof opening and flashing

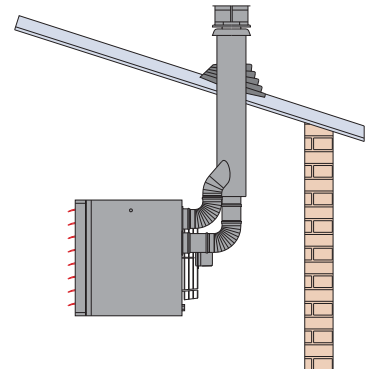

Balanced flue roof outlet (type C32)

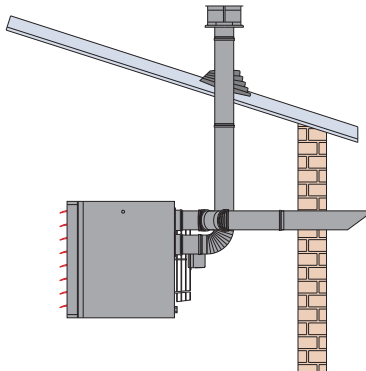

Combustion air through wall, flue outlet through the roof (type C52)

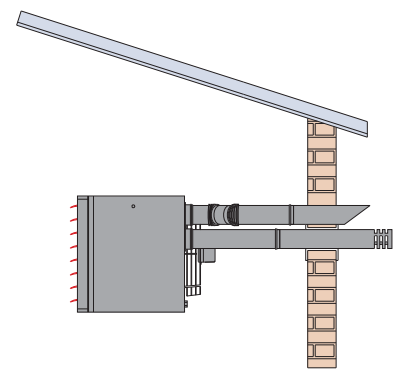

Separate combustion air and flue pipes (type C12) for applications where wall thickness exceeds 350mm. Flue and air intake to be offset

Heater positions and flue arrangements are indicative. For heater and flue clearances please refer to the manufacturer's guidelines.

## TECHNICAL DATA

Model			LCSA 35	LCSA 45	LCSA 60	LCSA 75
Heat output		kW	36	44	60	72
Gas consumption <sup>(1)</sup>	Nat. Gas G20	m <sup>3</sup> /h	4.2	5.2	7.0	8.4
	Propane G31	kg/h	3.1	3.8	5.2	6.2
Gas connection <sup>(2)</sup>		Rc	3/4"	3/4"	3/4"	3/4"
Air volume @ 15°C		m <sup>3</sup> /h	4400	4600	6700	7200
Temperature rise		K	24	28	26	29
Approx. throw <sup>(3)</sup>		m	24	25	30	32
Noise level (free field @ 5 metres) <sup>(4)</sup>		dB(A)	46	47	52	52
Noise level (typical installation @ 5 metres) <sup>(4)</sup>		dB(A)	53	54	59	59
Recommended mounting height to underside of heater <sup>(5)</sup>		m	3-3.5	3-3.5	3-4	3-4
Total electrical rating		kW	0.49	0.49	0.84	0.84
Net weight		kg	92	97	112	124

1 Natural gas G20 value 10.48kW/m<sup>3</sup> GCV, inlet gas pressure maximum 50mbar, minimum 17.5mbar.  
Propane G31 Calorific value 14.0kW/kg GCV, inlet gas pressure maximum 50mbar, minimum 37mbar.

2 Not supply line size.

3 Throw is dependent on mounting height, building height, room temperature and louvre setting.

4 Noise levels are dependent on heater location and type of building.

5 Recommended height to underside of heater for standard horizontal discharge units. Downturn nozzles are recommended for units installed at higher mounting heights. For buildings over 4 metres high, air re-circulation fans are recommended in conjunction with the heaters.

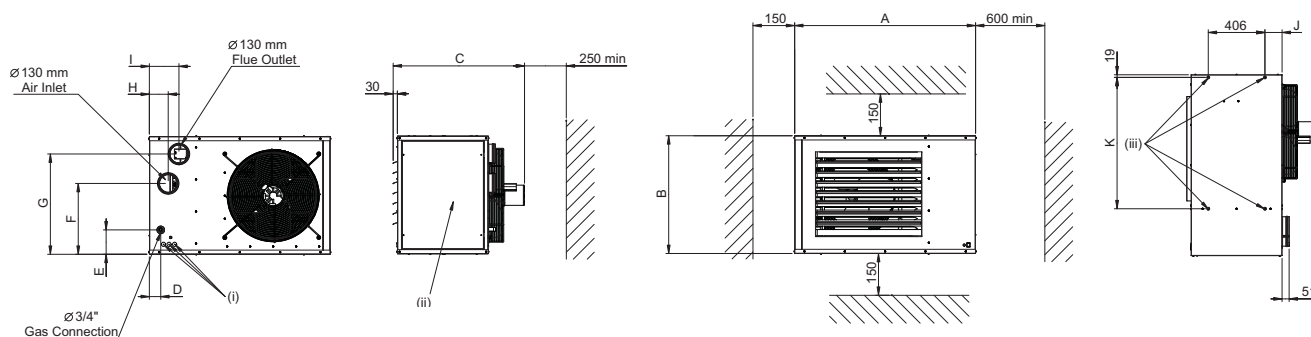

(i) Electrical Connections

(ii) Access Panel

(iii) Suspension Points (M10 Female)

## DIMENSIONS

Model			LCSA 35	LCSA 45	LCSA 60	LCSA 75
Cabinet width	A		965	965	1298	1298
Height	B		845	845	845	845
Overall length	C		927	927	942	942
Side to gas inlet	D		82	82	82	82
Base to gas inlet	E		175	175	175	175
Base to air inlet	F		508	508	508	508
Base to flue outlet	G		720	720	720	720
Side to air inlet	H		134	134	135	135
Side to flue outlet	I		211	211	212	212
Back to suspension point	J		123	123	123	123
Suspension centres	K		611	611	942	942

An AmbiRad Group brand



AmbiRad Limited Fens Pool Avenue  
Brierley Hill West Midlands DY5 1QA  
United Kingdom



Telephone: 01384 489700  
Facsimile: 01384 489707  
Email: marketing@ambirad.co.uk  
Website: www.ambirad.co.uk

**AMBIRAD**  
ENERGY EFFICIENT HEATING SYSTEMS

AmbiRad is a registered trademark of AmbiRad Limited. Because of continuous product innovation, AmbiRad reserves the right to change product specification without due notice.